



Cat. No. **B/A17**

BMW X3 F25 (excl. M30)

09/10-08/17

BMW X4 F26 (excl. M40)

04/14-

E20 E20*55R01/7*005540*00

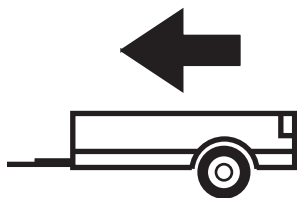



2400kg



100kg

D=12,11kN

$$D \text{ (kN)} = \frac{\text{MAX kg} \times \text{MAX kg}}{\text{MAX kg} + \text{MAX kg}} \times 0,00981$$

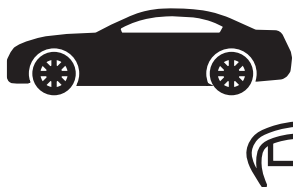



IMIOLA HAK-POL

96-111 KOWIESY, CHOJNATA 23A, POLAND

Tel. + 48 46 831 73 31, fax +48 831 74 29

e-mail: office@imiola.pl, www.imiola.pl

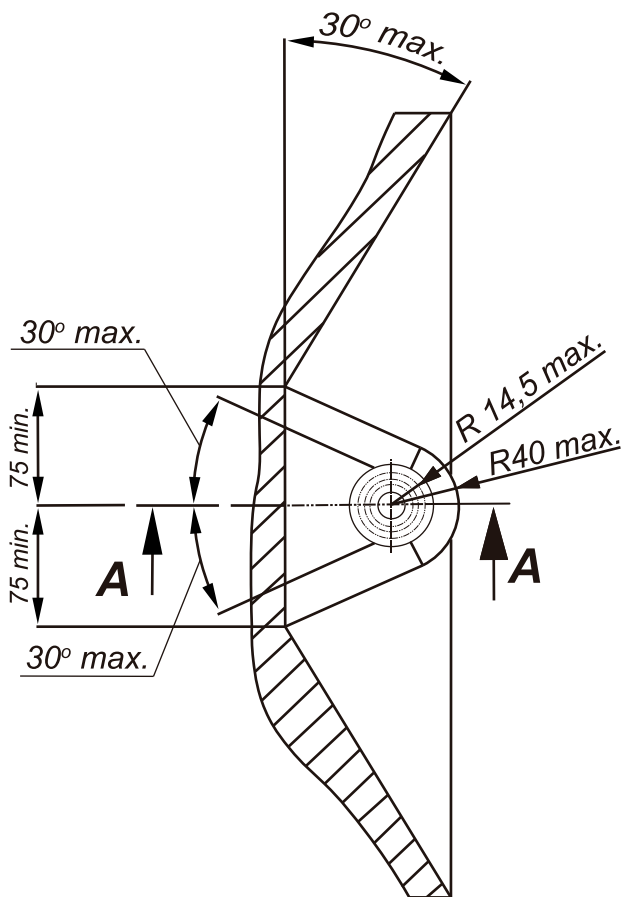

PRZEKRÓJ A-A

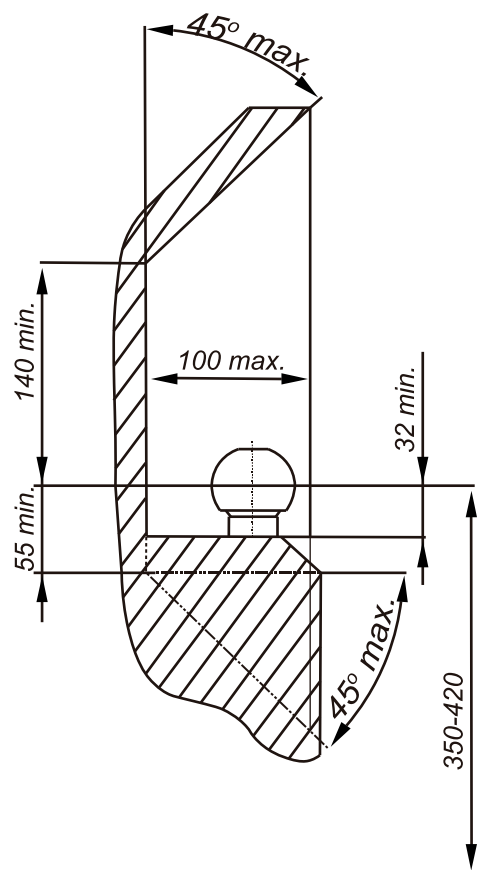

PL Należy zagwarantować przestrzeń swobodną według załącznika VII, rysunek 25a/b Regulaminu EKG ONZ 55.01 przy dopuszczalnym ciężarze całkowitym pojazdu.

F L'espace libre doit être garanti conformément à l'annexe VII, illustration de la réglementation 55.01 CE pour un poids total en charge autorisé du véhicule.





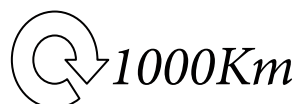

GB The clearance specified in appendix VII, diagram 25a/b of Regulation No. 55.01 UN EU must be guaranteed at laden weight of the vehicle.

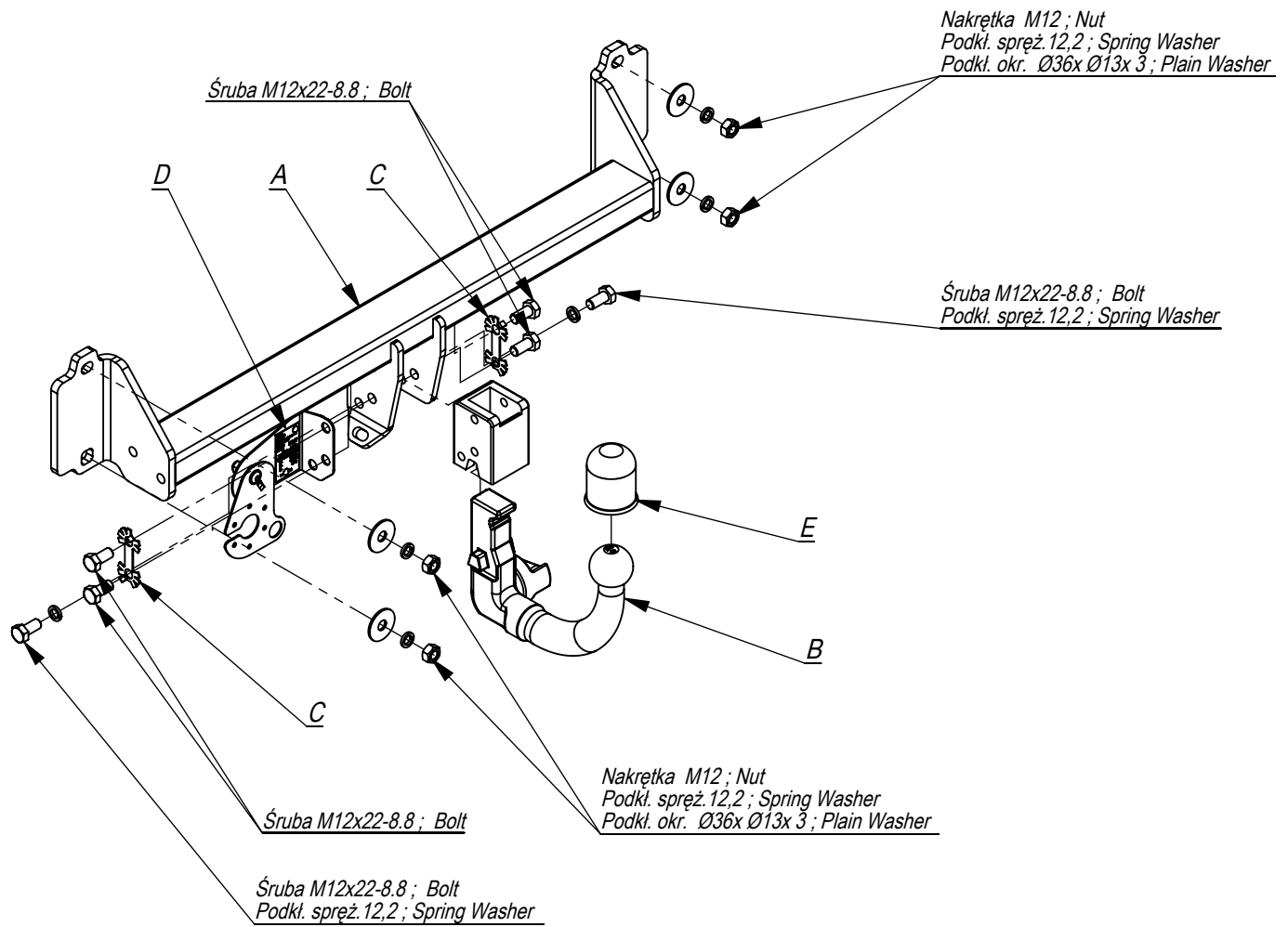
D Der Freiraum nach Anhang VII, Abbildung 25a/b der Vorschriften 55.01 EG ist zu gewährleisten bei zulässigem Gesamtgewicht des Fahrzeuges.

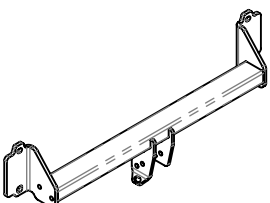
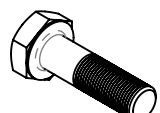
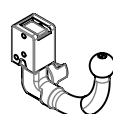
Moment skręcający dla śrub i nakrętek (8.8) Torque settings for nuts and bolts (8.8)	
M8	25Nm
M10	55Nm
M12	85Nm
M14	135Nm
M16	195Nm





	A	x1		M12x22	6
	B	x1		M12	4
	C	x2		Ø36xØ13x3	4
	D	x1		12,2	6
	E	x1			

- Odkręcić zderzak i lampy.
- Odkręcić belkę zderzeniową (nie będzie już wykorzystana). Przykręcić belkę haka A do tylnego pasa (pkt1).
- Dokręcić wszystkie śruby z momentem według tabeli.
- Wykonać wycięcie w środkowej części zderzaka na uchwyt kuli.
- Dokręcić kulę i blachę gniazda elektrycznego.
- Podłączyć instalację elektryczną.

- Unscrew the rear lights.
- Disassemble the bumper and its metal reinforcement (it will not be used any more).
- Put the main bar A to the rear belt of the car on the protruding original bolts and screw with nuts M12 (point 1)
- Tighten all the bolts according to the torque setting- see the table.
- Cut out the fragment in the lower part of the bumper to place the handles of the ball.
- Assemble the bumper.
- Connect the electric wires.
- Fix the ball and electric plate.

- Dévisser le pare-chocs et les lampes. Dévisser le renforcement de pare-chocs (il ne sera plus utilisé). Visser la barre de crochet e la jupe arriere (point 1).
- Serrer tous les boulons avec un couple de serrage selon tableau.
- Faire une coupe dans la partie centrale du pare-chocs sur la poignée de la balle.
- Serrer la boule et la tôle de la prise électrique.
- Brancher l'installation électrique.

- Die hinteren Leuchten demontieren
- Die Stoßstange und die Metallverstärkung abbauen (wird nicht wieder montiert).
- Den Querbalken A an den hinteren Karosseriestreifen auf die herausragenden Schrauben anlegen mit den Muttern M12 verschrauben (Punkt 1)
- Alle Schrauben mit dem in der Tabelle angegebenen Drehmoment anschrauben.
- Einen Ausschnitt im unteren Teil der Stoßstange für die Kugelgrie ausführen.
- Die Stoßstange einbauen.
- Die Elektroinstallation anschließen.
- Die Kugel und die Steckdosenhalterung anschrauben.

- Desenrosque las luces traseras.
- Desmontar el parachoques junto con el soporte metálico (no se montarán de nuevo)
- Coloque la barra de tracción A en la correa trasera del automóvil sobre los pernos originales que sobresalen y fíjela con las tuercas M12 (punto 1).
- Apretar todos los tornillos con el par según la tabla anterior.
- Hacer un corte en la parte inferior del parachoques para el soporte de la bola.
- Instalar el parachoques.
- Conectar la instalación eléctrica.
- Apretar la bola y la placa de la toma de corriente.

