

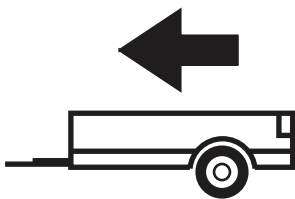

Cat. No. **B/A21**

BMW 1 (F20/F21) (excl. M1)	07/11-
BMW 2 Active Tourer (F45)	11/13-
BMW 2 (F22) (incl. M-Packet)	10/12-
BMW 2 Grand Tourer (F46)	07/14-
BMW 3 (F30) (excl. Active Hybrid) (incl. 4x4, M-Packet)	03/11-10/18
BMW 3 (F31) (incl. 4x4, M-Packet)	07/10-06/19
BMW 4 (F32,F33,F36)	07/13-

E20 E20 55R-01 5078





1944kg



100kg

D = 10,00kN

$$D \text{ (kN)} = \frac{\text{MAX kg} \times \text{MAX kg}}{\text{MAX kg} + \text{MAX kg}} \times 0,00981$$

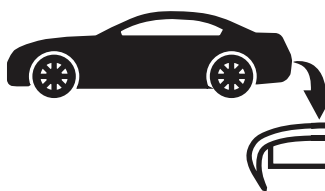



IMIOLA HAK-POL

96-111 KOWIESY, CHOJNATA 23A, POLAND

Tel. + 48 46 831 73 31, fax +48 831 74 29

e-mail: office@imiola.pl, www.imiola.pl

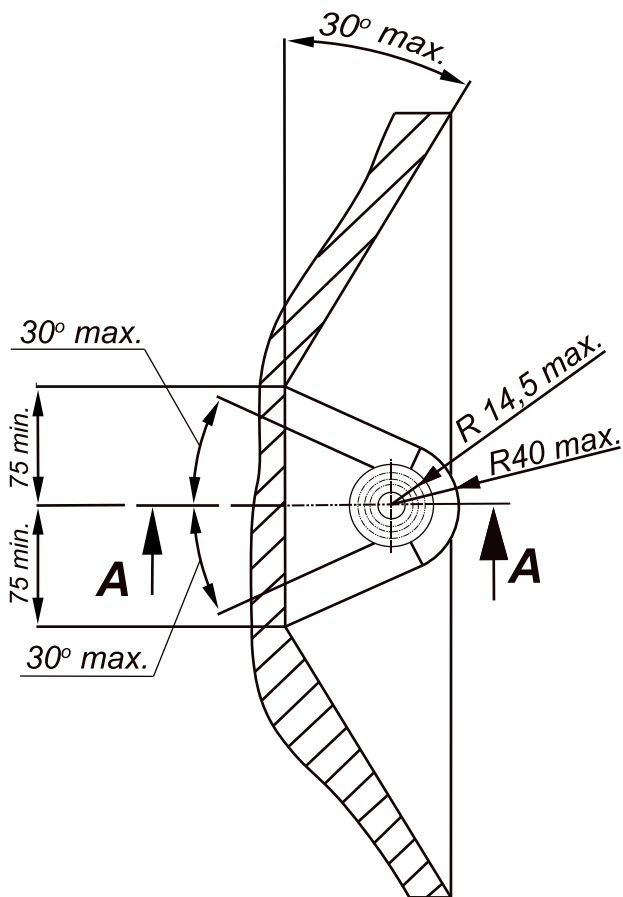

PRZEKRÓJ A-A

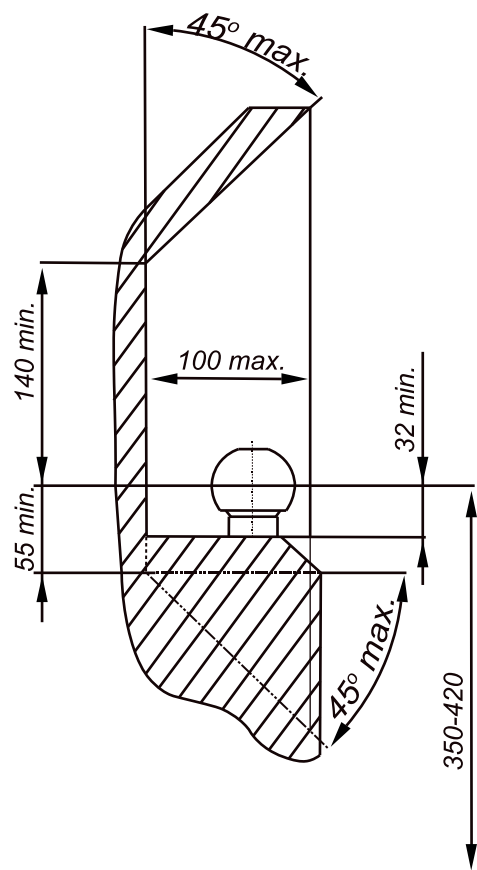

PL Należy zagwarantować przestrzeń swobodną według załącznika VII, rysunek 25a/b Regulaminu EKG ONZ 55.01 przy dopuszczalnym ciężarze całkowitym pojazdu.

F L'espace libre doit être garanti conformément à l'annexe VII, illustration de la réglementation 55.01 CE pour un poids total en charge autorisé du véhicule.

GB The clearance specified in appendix VII, diagram 25a/b of Regulation No. 55.01 UN EU must be guaranteed at laden weight of the vehicle.

D Der Freiraum nach Anhang VII, Abbildung 25a/b der Vorschriften 55.01 EG ist zu gewährleisten bei zulässigem Gesamtgewicht des Fahrzeuges.

Moment skręcający dla śrub i nakrętek (8.8) Torque settings for nuts and bolts (8.8)	
M8	25Nm
M10	55Nm
M12	85Nm
M14	135Nm
M16	195Nm

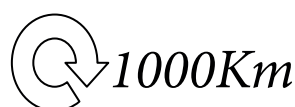

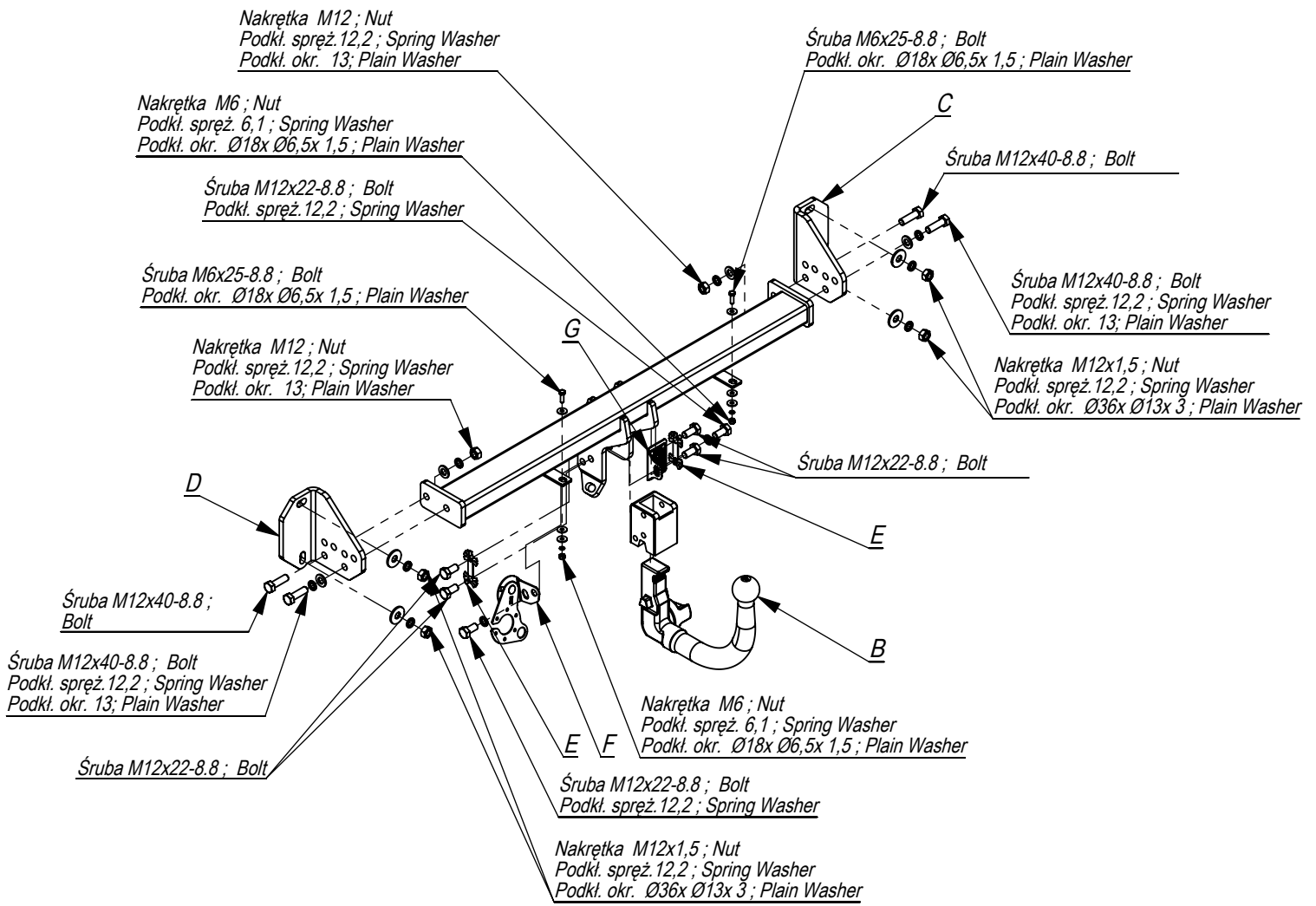

	A	x1		M12x40	4
				M12x22	6
				M6x25	2
	B	x1		M12	2
				M12x1,5 ^{original car nut}	4
				M6	2
	C	x1		Ø36xØ13x3	4
				Ø18xØ6,5x1,5	6
	D	x1		13	4
	E	x2		12,2	10
				6,1	2
	F	x1			
	G	x1			

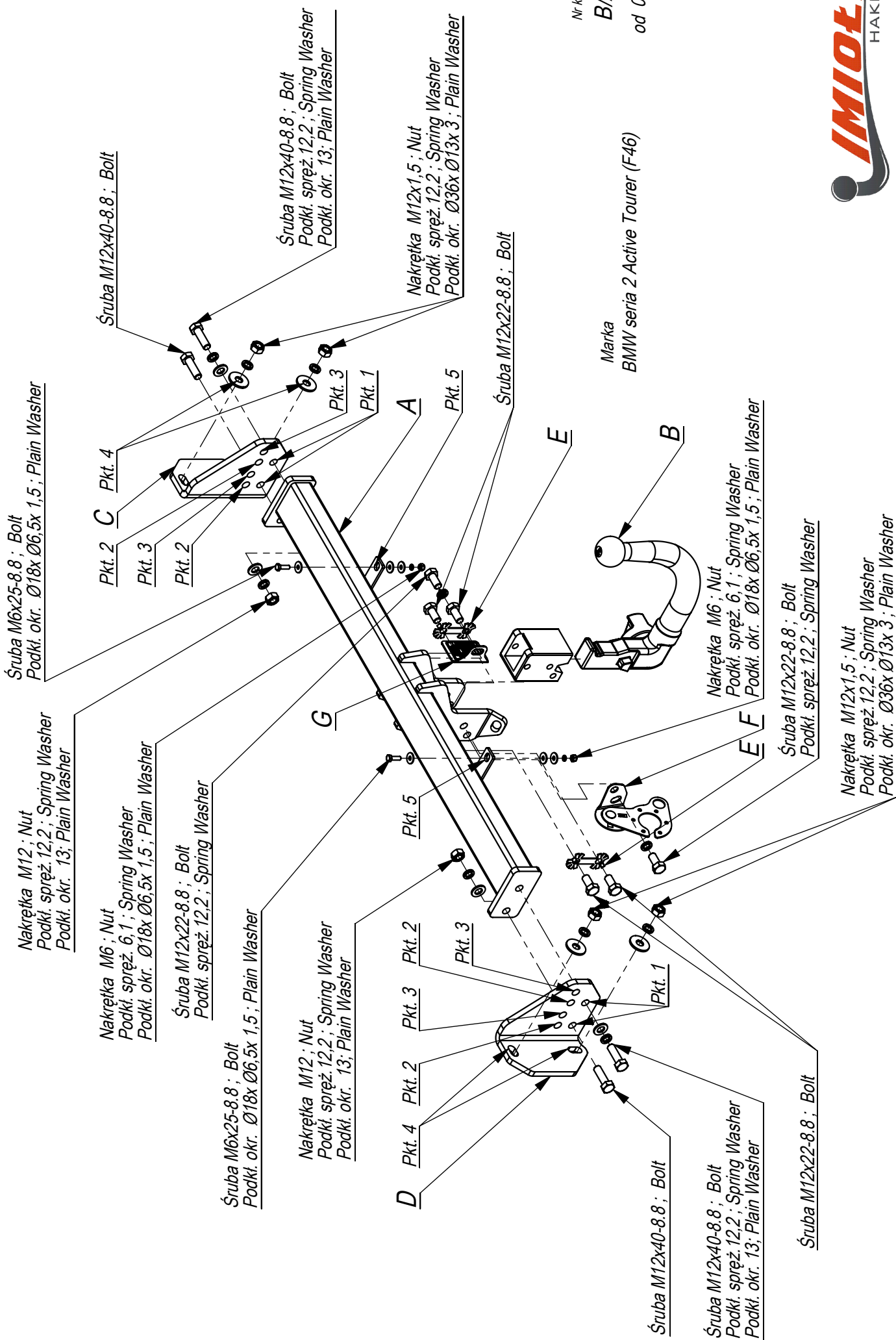

Nr katalogowy
B/A21
 od 03/2014 ->

Marka
BMW seria 2 Active Tourer (F46)



96-III Kowiesy, Chojnata 23 A
 tel. +48 46 831 73 31

- Odkręcić zderzak, lampy oraz dolną osłonę.
- Odkręcić belkę zderzeniową (nie będzie wykorzystana) .
- Udzielić otwory w podłużnicach.
- Elementy C i D przykręcić do tylnego pasa nakrętkami M12 stosując podkładki powiększone (pkt 4).
- Belkę haka przykręcić odpowiednio: 1 i 2 Series (pkt 1); 3 i 4 Series (pkt 2); 2 Active Tourer (rys. 2) śrubami M12x40 8.8.
- W dolnej osłonie wykonać wycięcie na szerokość uchwytu kuli oraz gniazda elektrycznego.
- Przykręcić dolną osłonę, zderzak i lampy. (pkt. 5)
- Dokręcić wszystkie śruby z momentem według tabeli.
- Dokręcić kulę i blachę gniazda elektrycznego.
- Podłączyć instalację elektryczną.

- Unscrew the bumper, lamps and lower shield.
- Unscrew the bumper bar (it will not be used any more).
- Clean out the holes in the frame side members.
- Screw the elements C and D to the rear belt with nuts M12 using large washers (point 4).
- Screw the main bar accordingly:
1 and 2 Series (point 1), 3 and 4 Series (point 2), 2 Active Tourer (drawing 2) with bolts M12x40 8.8.
- Cut out the fragment in the lower shield to put the towball handles and electric plate.
- Assemble the lower shield, bumper and lamps. (point 5)
- Tighten all the bolts according to the torque setting- see the table.
- Fix the ball and electric plate.
- Connect the electric wires.

- Dévisser le pare-chocs, les lampes et la protection inférieure.
- Dévisser la poutre pare-chocs (non utilisée ultérieurement).
- Déboucher les orifices dans les longerons.
- Visser les éléments C et D à la jupe arrière avec des écrous M12, en utilisant des rondelles agrandies (pt 4).
- Visser la barre du crochet respectivement: 1 et 2 Series(pt 1); 3 et 4 Series (pt 2); Active Tourer (fig 2) par vis M12x40 8.8.
- Exécuter une encoche dans la protection inférieure, sur la largeur d'encastrement de la boule et de la prise électrique. Visser la protection inférieure, le pare-chocs et les lampes . (pt 5)
- Serrer tous les boulons avec un couple de serrage selon tableau.
- Serrer la boule et la tôle de la prise électrique.
- Raccorder le circuit électrique.

- Die Stoßstange abschrauben.
- Die Stoßstange Verstärkung abschrauben, wird nicht wieder montiert.
- Die Bauteile C und D an den hinteren Karosseriestreifen anlegen mit den Muttern M12 anschrauben (Punkt 1).
- Schrauben Sie die AHK-Träger A entsprechend fest: 1 and 2 Series (punkt 1), 3 and 4 Series (punkt 2), 2 Active Tourer (Illustration 2) with bolts M12x40 8.8.
- In der Stoßstange einen Ausschnitt für die Klappen der Kugel ausführen.
- Montieren Sie die untere Abschirmung, den Stoßfänger und die Lampen. (punkt 5)
- Die Kugel und die Steckdosenhalterung mit den Schrauben M12x22 anschrauben.
- Alle Schrauben mit dem in der Tabelle angegebenen Drehmoment anschrauben.
- Die Elektroinstallation anschließen.

- Desenroscar el parachoques.
- Desenroscar el realzar del parachoques (ya no se montará).
- Fijar los elementos C y D la correa trasera del automovil sobre y apretar con tuercas M12 (punto 1).
- Atornille la barra principal en consecuencia: 1 and 2 Series (punto 1), 3 and 4 Series (punto 2), 2 Active Tourer (dibujo 2) with bolts M12x40 8.8.
- Hacer un corte en el parachoques para las garras de la bola.
- Assemble the lower shield, the bumper and the lamps. (punto 5)
- Apretar la bola y la placa de la toma de corriente tornillos M12x22.
- Apretar todos los tornillos con el par según la tabla anterior.
- Conectar la instalación eléctrica..

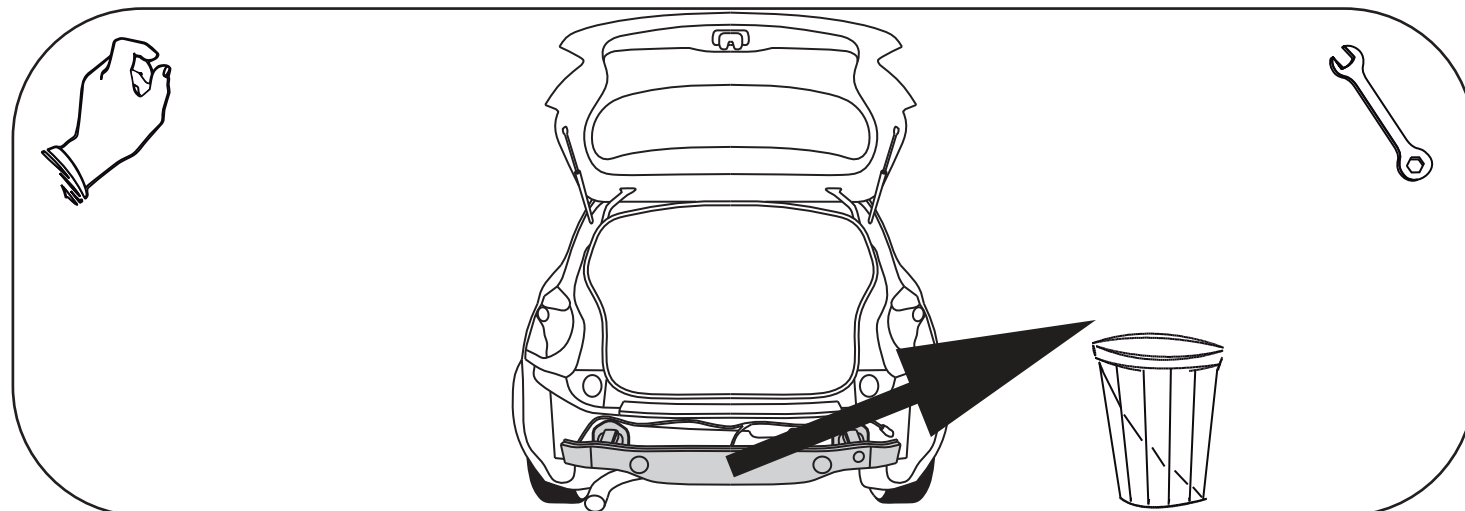
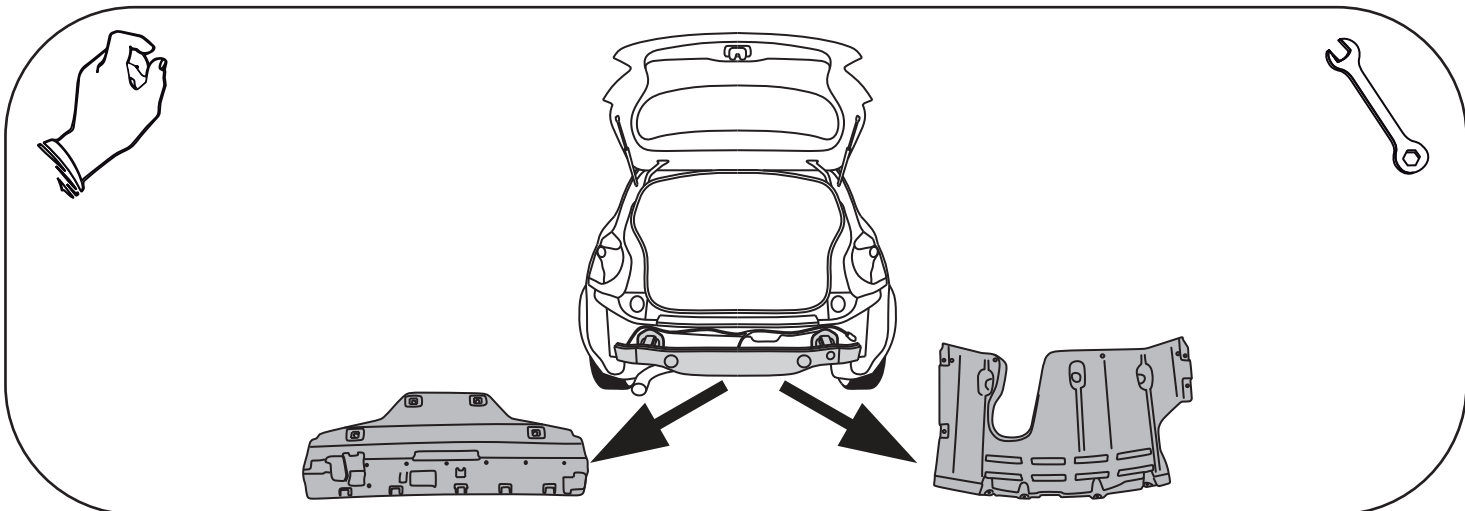
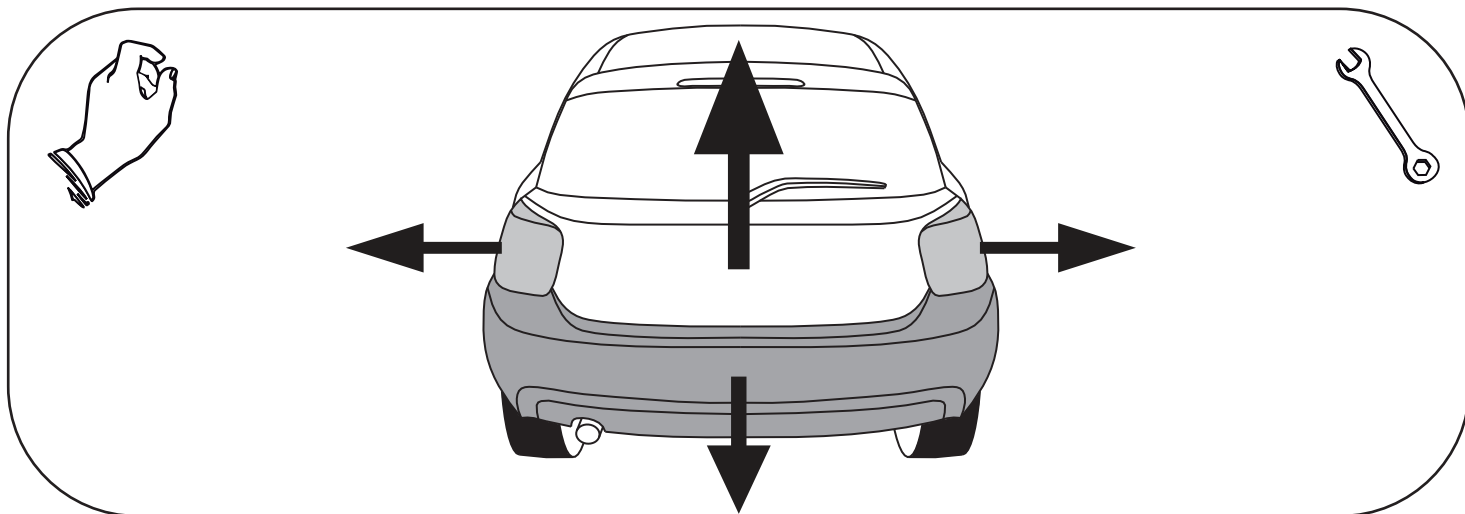

BMW serie 1
BMW serie 2

12,2 x4

Ø36xØ13x3 x4

M12x1,5 x4

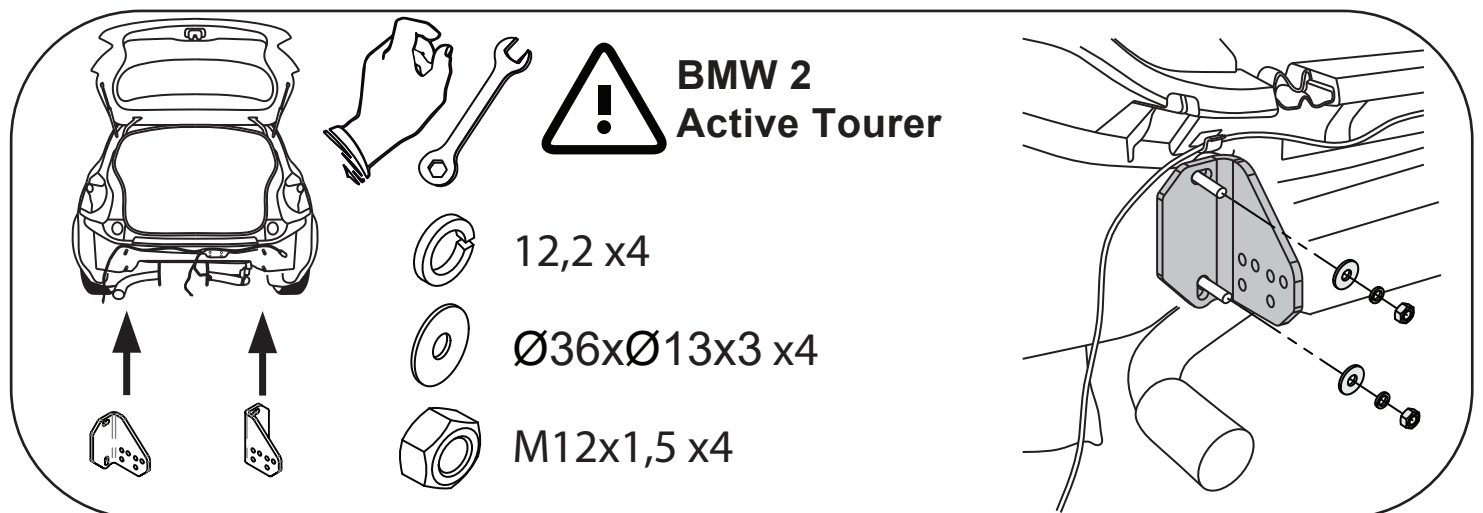
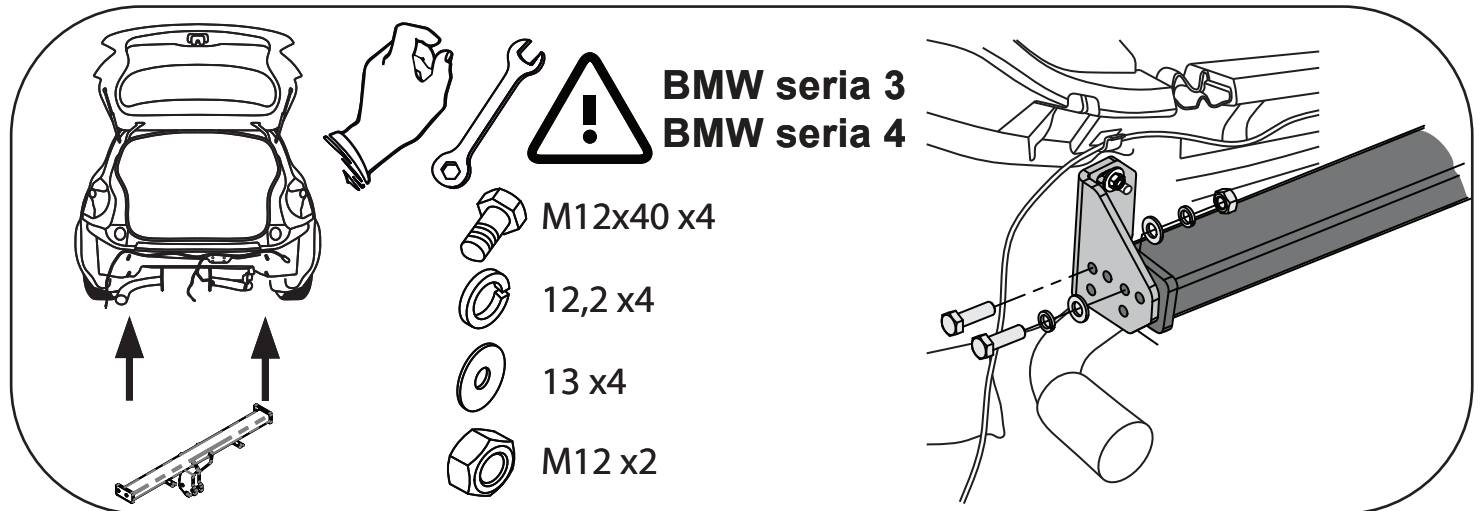
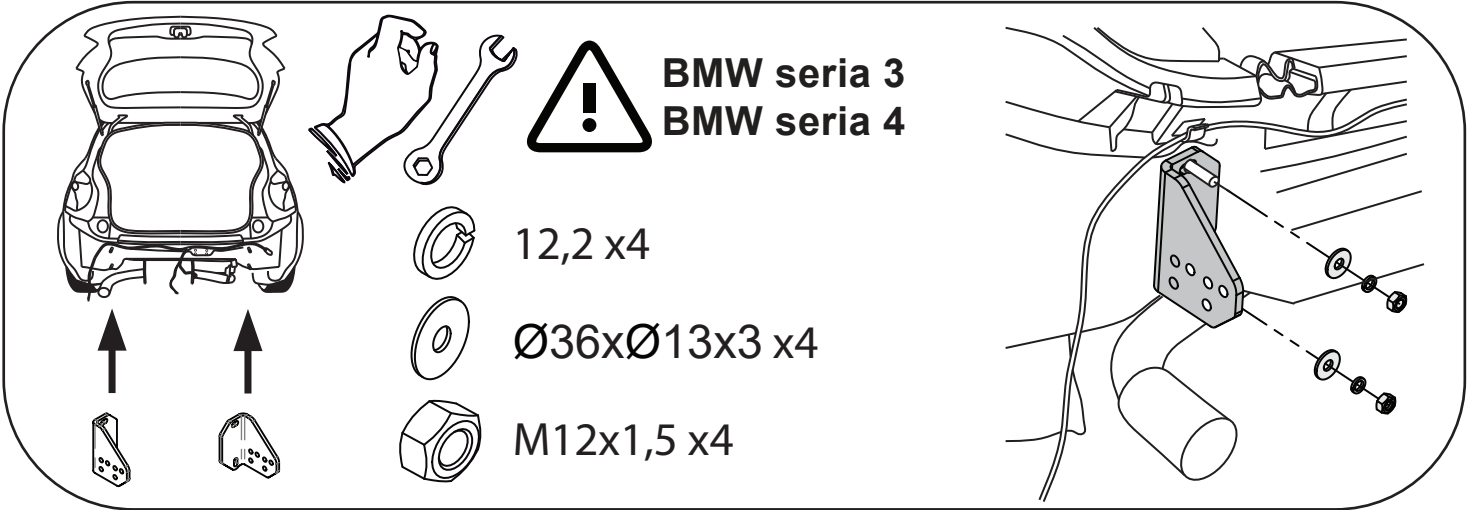
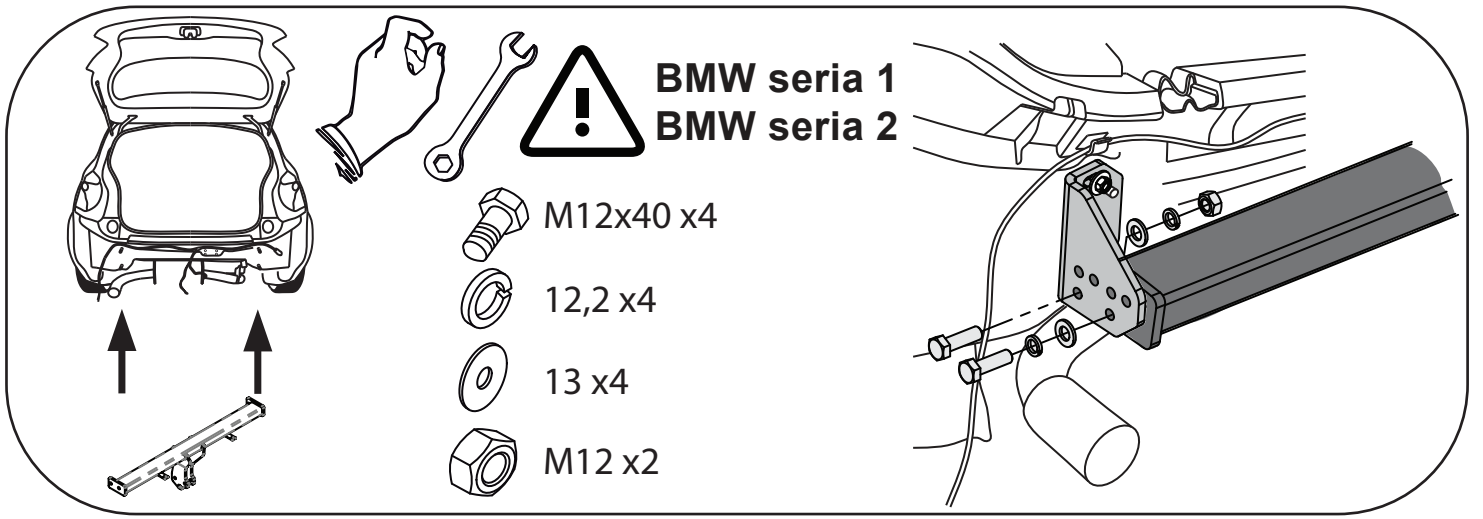

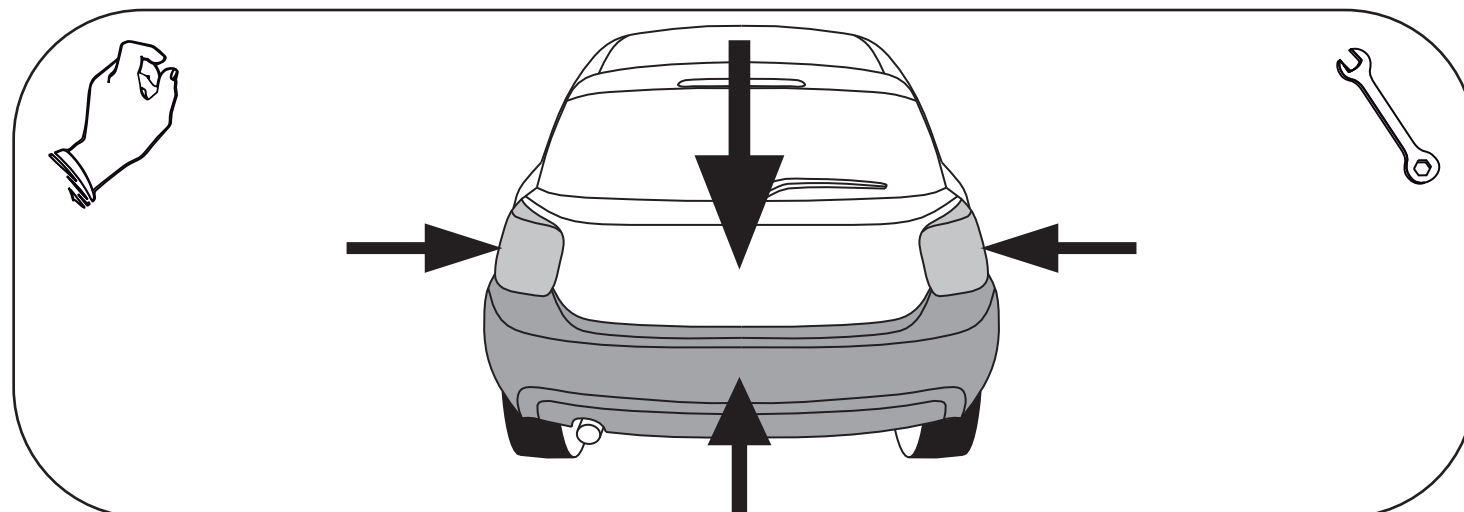
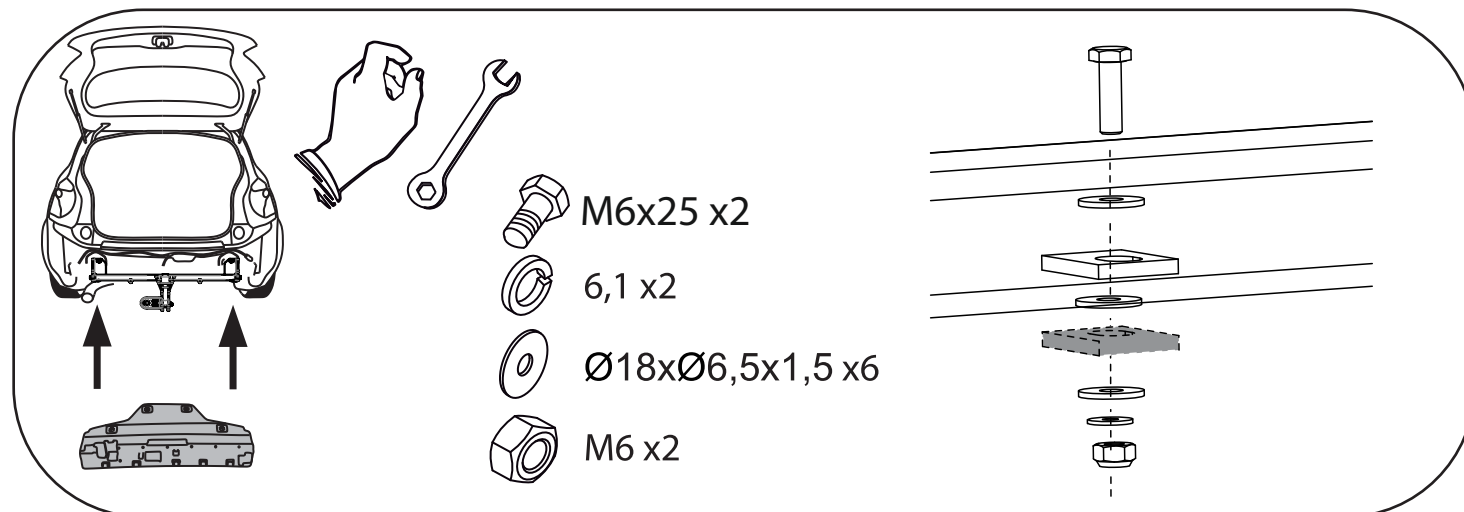
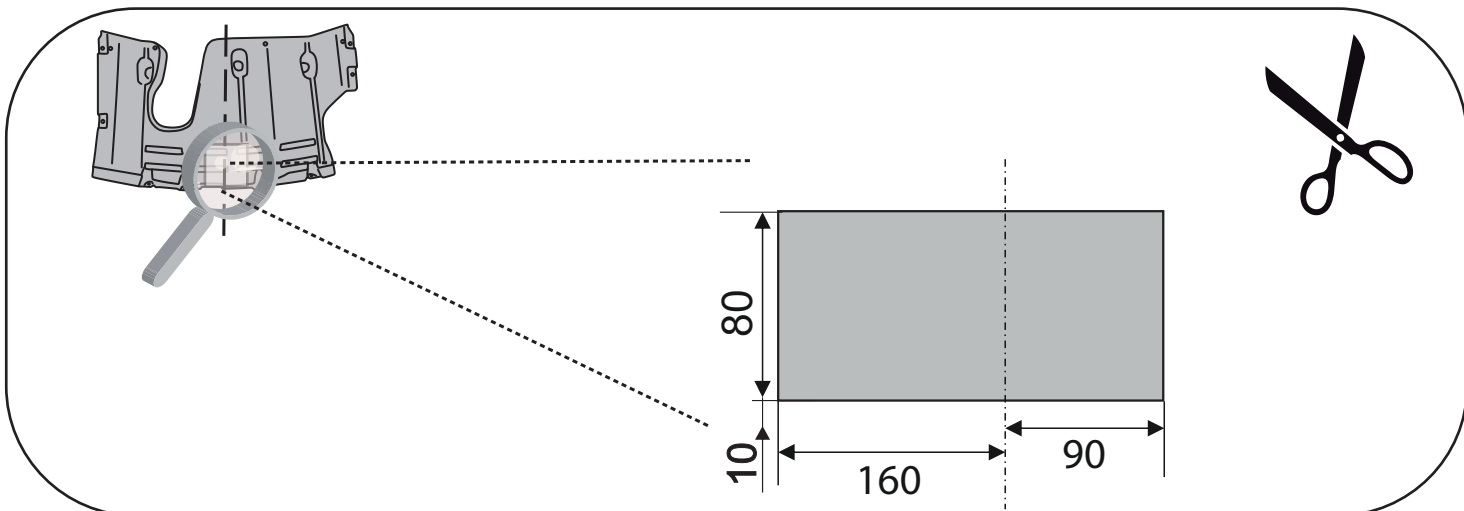
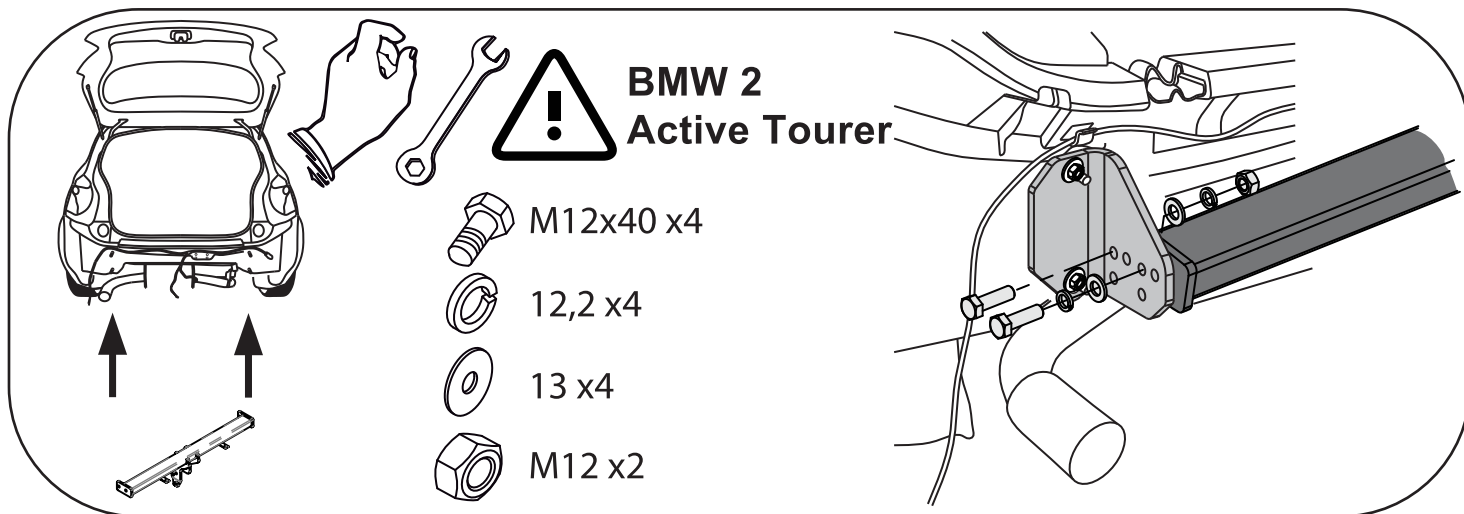

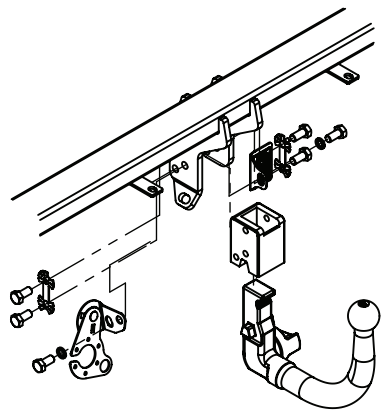
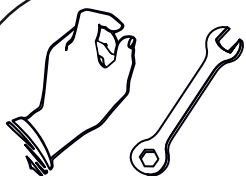

M12x22 x6



12,2 x2



F x2



CRIMP

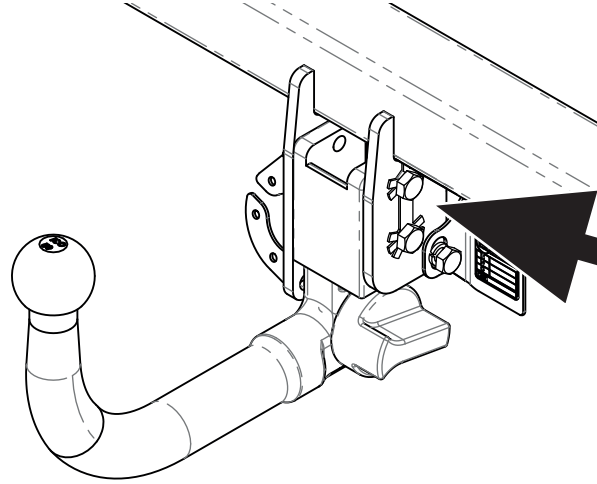
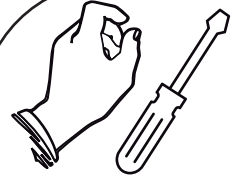
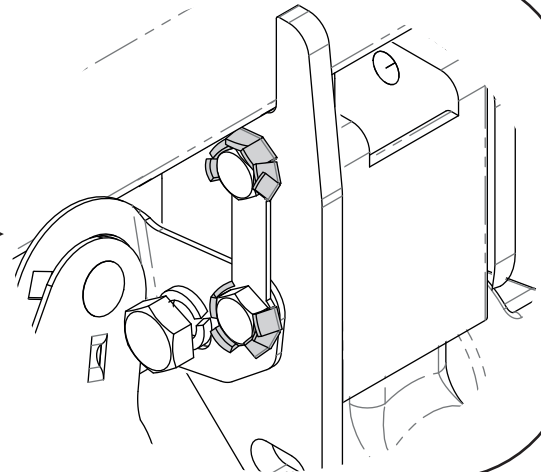
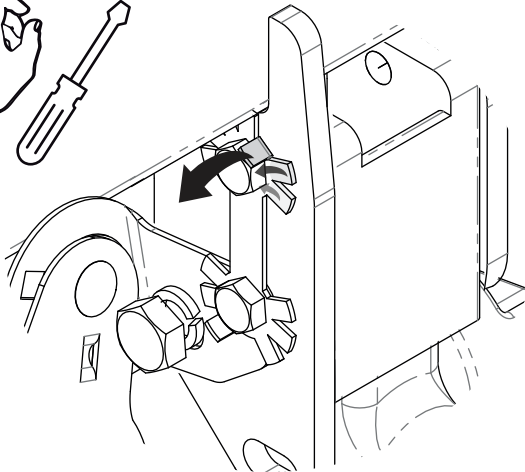
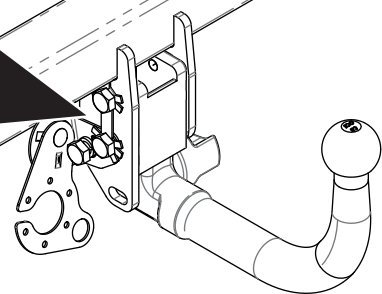

CRIMP

