



FIAT SCUDO II
CITROEN JUMPY II
PEUGEOT EXPERT II

2007 -

Cat. No. **F/023**

e20

e20*94/20*0714*00

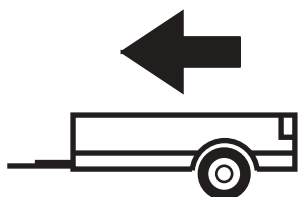

2000kg

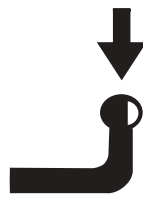

80kg

D = 11,93kN

D (kN) =



MAX kg

x

MAX kg

x 0,00981



MAX kg

+

MAX kg



IMIOLA HAK-POL

96-111 KOWIESY, CHOJNATA 23A, POLAND

Tel. + 48 46 831 73 31, fax +48 831 74 29

e-mail: office@imiola.pl, www.imiola.pl



PRZEKRÓJ A-A

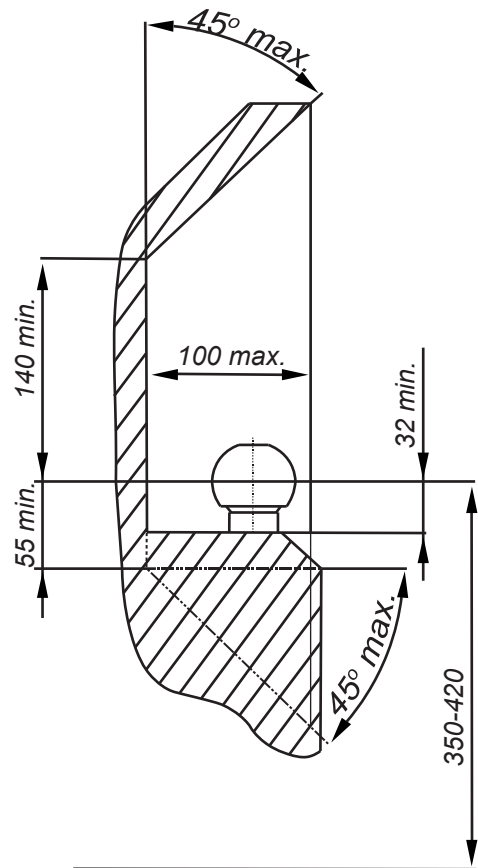

PL Należy zagwarantować przestrzeń swobodną według załącznika VII, rysunek 25a/b Regulaminu EKG ONZ 55.01 przy dopuszczalnym ciężarze całkowitym pojazdu.

F L'espace libre doit être garanti conformément à l'annexe VII, illustration de la réglementation 55.01 CE pour un poids total en charge autorisé du véhicule.









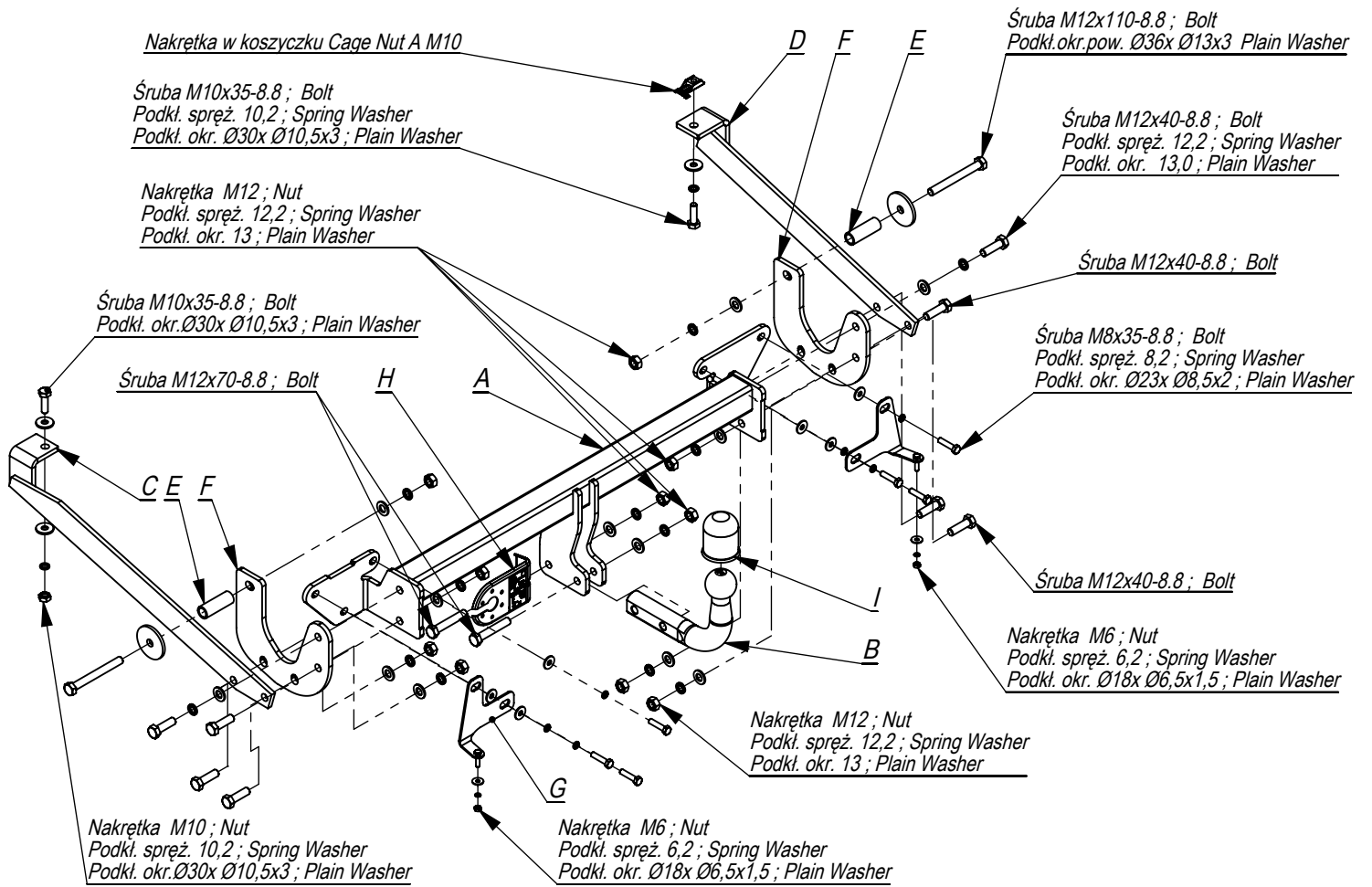

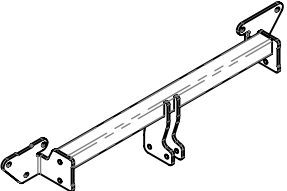



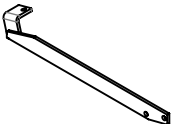

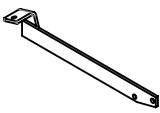
GB The clearance specified in appendix VII, diagram 25a/b of Regulation No. 55.01 UN EU must be guaranteed at laden weight of the vehicle.

D Der Freiraum nach Anhang VII, Abbildung 25a/b der Vorschriften 55.01 EG ist zu gew 25a/bahrleisten bei zulässigem Gesamtgewicht des Fahrzeuges.

Moment skręcający dla śrub i nakrętek (8.8) Torque settings for nuts and bolts (8.8)	
M8	25Nm
M10	55Nm
M12	85Nm
M14	135Nm
M16	195Nm

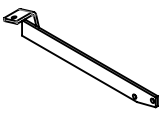

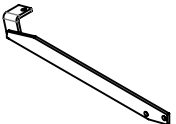

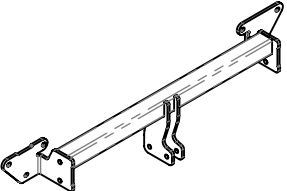
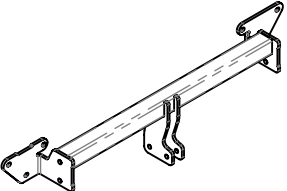
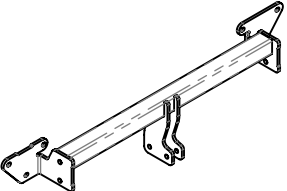
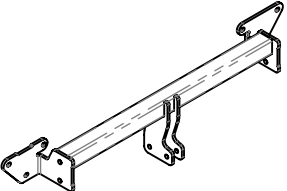
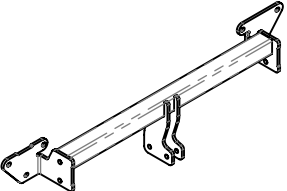
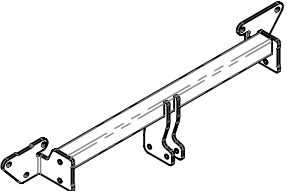
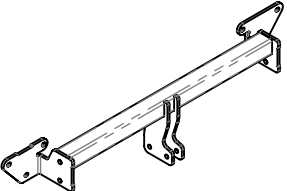
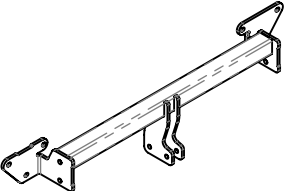
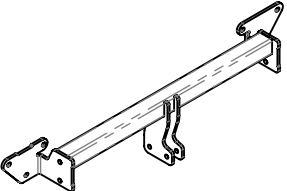
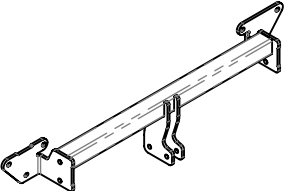
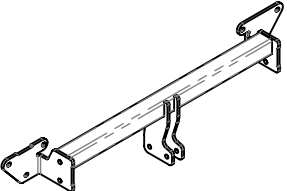
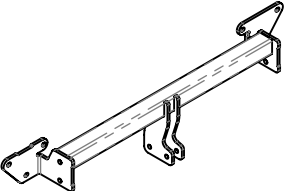
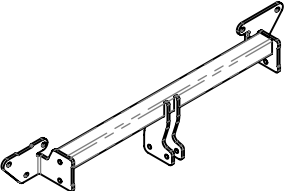
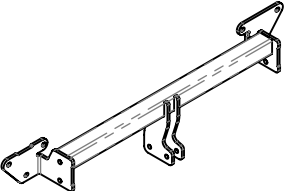
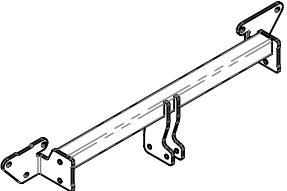
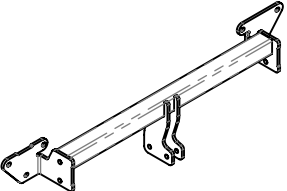
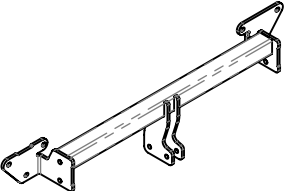
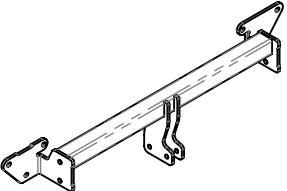
	A	x1			
	B	x1			
	C	x1			
	D	x1			
	E	x2			
	F	x2			
	G	x1			
	H	x1			
	I	x1			
				M12x110	2
				M12x70	2
				M12x40	8
				M10x35	2
				M8x35	6
				M12	10
				M10	1
				M6	2
				Ø36xØ13x3	2
				Ø30xØ10,5x3	3
				Ø23xØ8,5x2	6
				Ø18xØ6,5x1,5	2
				13	12
				12,2	12
				10,2	2
				8,2	6
				6,1	2
				M10	1

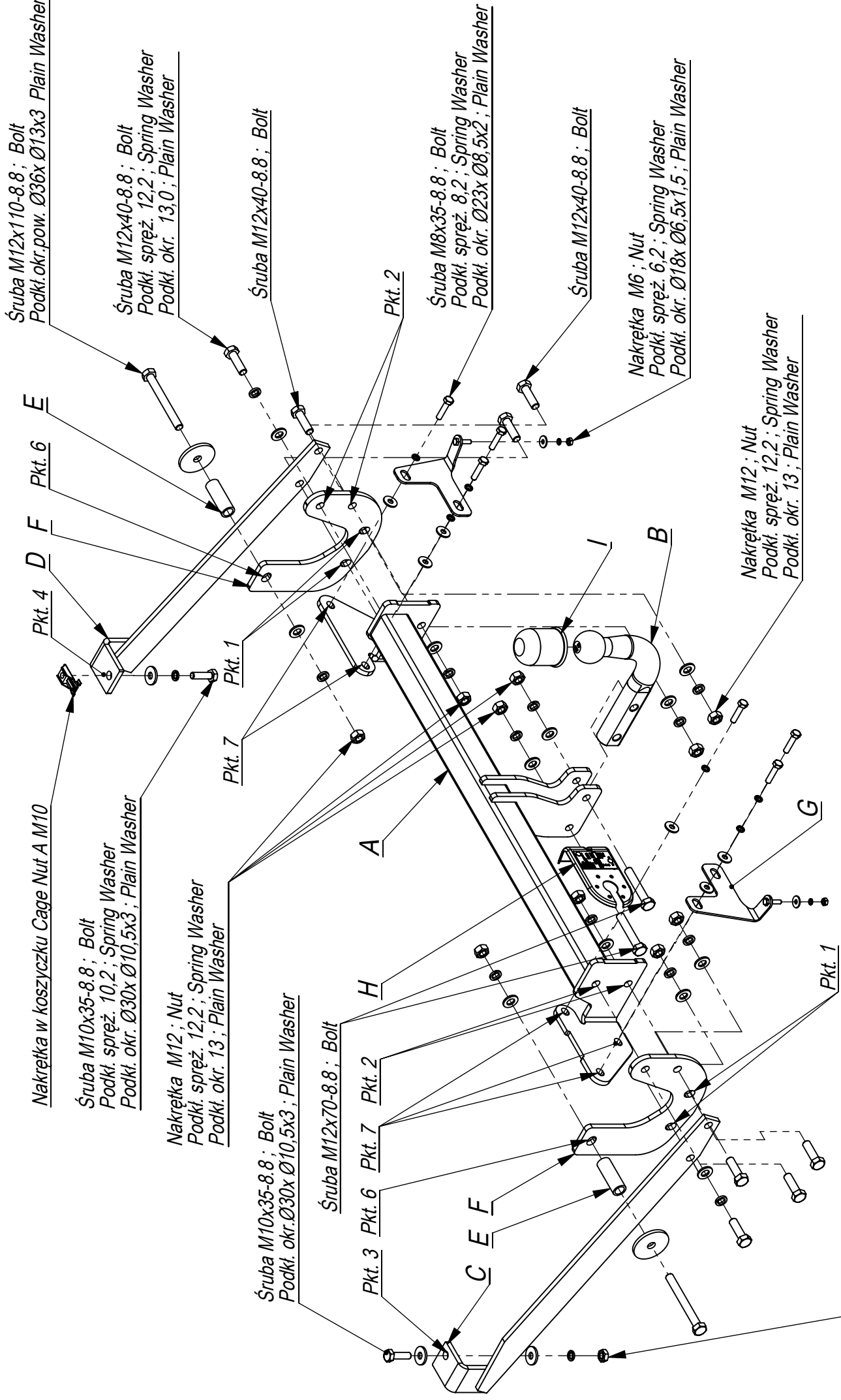

Śruba M12x110-8.8 ; Bolt
Podkl. okr.pow. Ø36x Ø13x3 Plain Washer

Śruba M12x40-8.8 ; Bolt
Podkl. spręż. 12,2 ; Spring Washer
Podkl. okr. 13,0 ; Plain Washer

Śruba M12x40-8.8 ; Bolt

Śruba M8x35-8.8 ; Bolt
Podkl. spręż. 8,2 ; Spring Washer
Podkl. okr. Ø23x Ø8,5x2 ; Plain Washer

Śruba M12x40-8.8 ; Bolt

Nakrętka M6 ; Nut
Podkl. spręż. 6,2 ; Spring Washer
Podkl. okr. Ø18x Ø6,5x1,5 ; Plain Washer

Nakrętka M12 ; Nut
Podkl. spręż. 12,2 ; Spring Washer
Podkl. okr. 13 ; Plain Washer

Nakrętka w koszyczku Cage Nut A M10

Śruba M10x35-8.8 ; Bolt
Podkl. spręż. 10,2 ; Spring Washer
Podkl. okr. Ø30x Ø10,5x3 ; Plain Washer

Nakrętka M12 ; Nut
Podkl. spręż. 12,2 ; Spring Washer
Podkl. okr. 13 ; Plain Washer

Śruba M10x35-8.8 ; Bolt
Podkl. okr.Ø30x Ø10,5x3 ; Plain Washer

Śruba M12x70-8.8 ; Bolt

Nakrętka M10 ; Nut
Podkl. spręż. 10,2 ; Spring Washer
Podkl. okr.Ø30x Ø10,5x3 ; Plain Washer

od 10.2006 ->

Nr katalogowy
F/023

Marka
Fiat Scudo II
Citroen Jumpy III, Peugeot Expert II



96-111 Kowiesy, Chojnata 23 A
tel. +48 46 831 73 31

- Hak należy zamontować w fabryczne otwory zaklejone plastrem w kolorze podwozia. Plastry należy zerwać.
- W technologiczne otwory należy włożyć specjalne wkładki z nakrętkami.
- Belkę haka A przykręcić do tylnego pasa i boków podłużnic śrubami M8x35 8.8 (pkt 7).
- Elementy haka F przykręcić do boków podłużnic śrubami M12x110 8.8 stosując tulejki E (pkt 6) oraz skręcić śrubami M12x45 8.8 z belką haka A (pkt 2).
- Elementy haka C i D przykręcić do elementów F śrubami M12x45 8.8 (pkt 1) oraz do podłużnic śrubami M10x35 8.8 (pkt 4).
- Dokręcić wszystkie śruby z momentem wg tabeli.
- Przykręcić kulę i blachę gniazda elektrycznego śrubami M12x70 8.8.
- Podłączyć instalację elektryczną.

- The towbar should be install in the technological points stucked with slice in colour of the chassis. Is necessary to open this holes.
- Put special nuts "Caget nuts" in the technological holes.
- Screw the main bar A to the rear belt and sides of the metal clamps with bolts M8x35 8.8 (points 7).
- Screw the elements F to the sides of the metal clamps with bolts M12x110 8.8 using sleeves E (point 6) and screw to the main bar A with bolts M12x45 8.8 (point 2).
- Screw the elements C and D to the elements F with bolts M12x45 8.8 (point 1) and to the metal clamps with bolts M10x35 8.8 (point 4).
- Tighten all the bolts according to the torque setting- see the table.
- Fix the ball and electric plate with bolts M12x70 8.8.
- Connect the electric wires.

- Monter le crochet dans les ouvertures d'usine, collées par le scotch en couleur de châssis. Détacher les scotchs.
- Insérer les plaquettes spéciales avec les écrous dans les ouvertures.
- Serrer la traverse de crochet A a la partie arriere et aux flancs des longerons par les boulons M8x35 8.8 (point 7).
- Serrer les éléments de crochet F aux flancs des longerons avec les boulons M12x110 8.8 par les douilles E (point 6) et serrer avec les boulons M12x45 8.8 a la traverse de crochet A (point 2).
- Visser l'élément C et D au crochet F par le boulon M12x35 8.8 (point 1) et a la traverse de crochet par les boulons M10x35 8.8 (point 4).
- Serrer tous les boulons avec un couple de serrage selon tableau.
- Visser la boule et tôle de la prise électrique par les boulons M12x70 8.8.
- Raccorder le circuit électrique.

- Die Anhängerkupplung in den vom Werk aus vorhandenen Öffnungen verklebten mit einem Pflaster in Gestellfarbe, montieren.
- In die vom Werk aus vorhandenen Öffnungen, die speziellen Einlagen mit den Muttern einlegen.
- Den Querbalken A an den hinteren Karosseriestreifen und an die Längsträgerseiten mit den Schrauben M8x35 8.8 (Punkt 7) anschrauben.
- Die Tragteile F an Längsträgerseiten mit den Schrauben M12x110 8.8, mit der Anwendung von den Hülsen E (Punkt 6) und mit den Schrauben M12x45 8.8, mit dem Querbalken A (Punkt 2) verschrauben.
- Die Tragteile C und D an die Tragteile F mit den Schrauben M12x45 (Punkt 1) und an die Längsträger mit den Schrauben M10x35 8.8 (Punkt 4) anschrauben.
- Alle Schrauben mit dem in der Tabelle angegebenen Drehmoment festziehen.
- Die Kugel und die Steckdosenhalterung mit den Schrauben M12x70 8.8 anschrauben.
- Die Elektroinstallation anschließen.

- Retire la cinta que cubre los agujeros de fábrica en los largueros.
- Inserte la Cuget Nut M10 en los largueros a través de las aberturas de fábrica.
- Apretar una barra el gancho de remolque A con los tornillos M8x35 8.8 (punto 7).
- Fijar los elementos F a los largueros con tornillos M12x110 8.8 utilizando elementos E (Punto 6) y los tornillos M12x45 8.8 el gancho de remolque A(Punto 2).
- Fijar los elementos C y D a los elementos F con tornillos M12x45 8.8 (punto 1) y a los largueros con tornillos M10x35 8.8 (Punto 4).
- Montar el parachoques y las luces.
- Apretar todos los tornillos con el par según la tabla anterior.
- Apretar la bola y la placa de la toma eléctrica.
- Conectar la instalación eléctrica.

