



HYUNDAI SANTA FE

2001 - 2005

Cat. No. J/018

e20

e20*94/20*0911*00

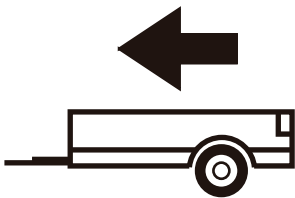

2 300kg



90kg

D = 11,52kN

D (kN) =



MAX kg

x

MAX kg

x 0,00981



MAX kg

+

MAX kg

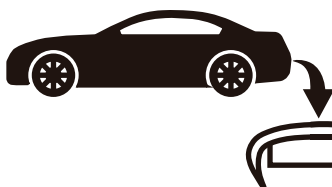

IMIOLA HAK-POL

96-111 KOWIESY, CHOJNATA 23A, POLAND

tel. +48 46 831 73 31, fax +48 831 74 29

e-mail: office@imiola.pl, www.imiola.pl

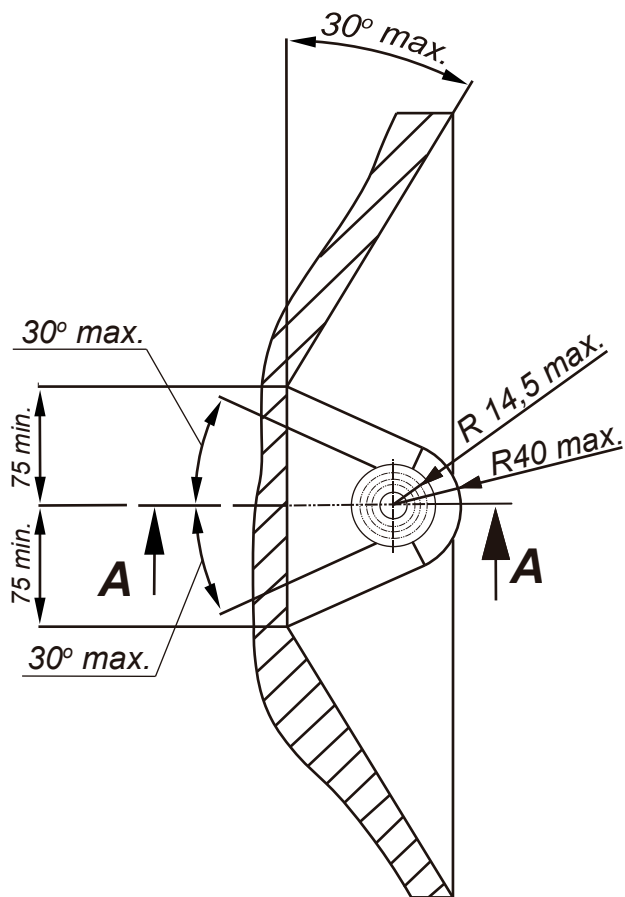

PRZEKRÓJ A-A

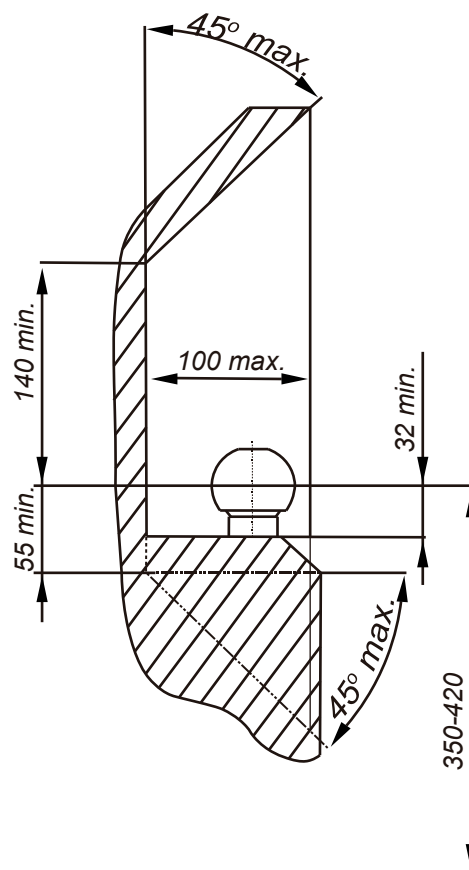

PL Należy zagwarantować przestrzeń swobodną według załącznika VII, rysunek 25a/b Regulaminu EKG ONZ 55.01 przy dopuszczalnym ciężarze całkowitym pojazdu.

F L'espace libre doit être garanti conformément à l'annexe VII, illustration de la réglementation 55.01 CE pour un poids total en charge autorisé du véhicule.

GB The clearance specified in appendix VII, diagram 25a/b of Regulation No. 55.01 UN EU must be guaranteed at laden weight of the vehicle.







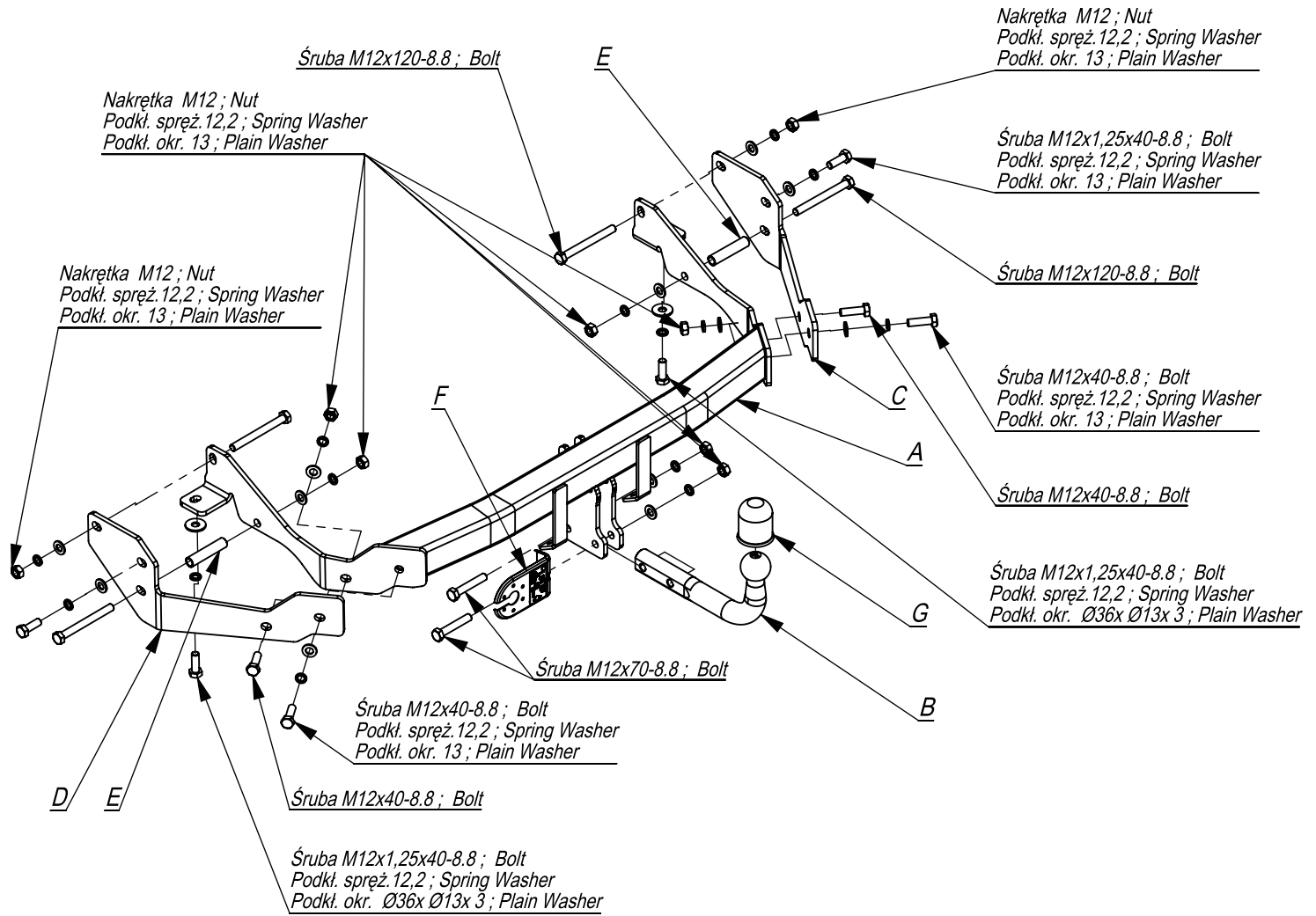

D Der Freiraum nach Anhang VII, Abbildung 25a/b der Vorschriften 55.01 EG ist zu gew 25a/b abzugeben bei zulässigem Gesamtgewicht des Fahrzeuges.

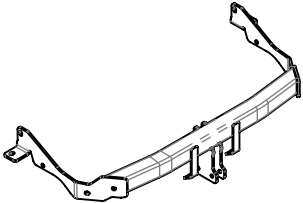
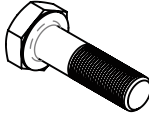
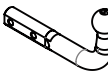
Moment skrecający dla śrub i nakrętek (8.8) Torque settings for nuts and bolts (8.8)

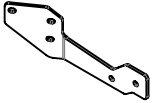
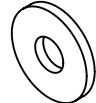
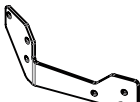
M8	25Nm
M10	55Nm
M12	85Nm
M14	135Nm
M16	195Nm

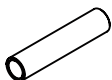



	A	x1		M12x120	4
				M12x70	2
				M12x40	4
				M12x1,25x40	4
	B	x1		M12	8
	C	x1		Ø36xØ13x3	2
	D	x1		13	12
	E	x2		12,2	14
	F	x1			
	G	x1			

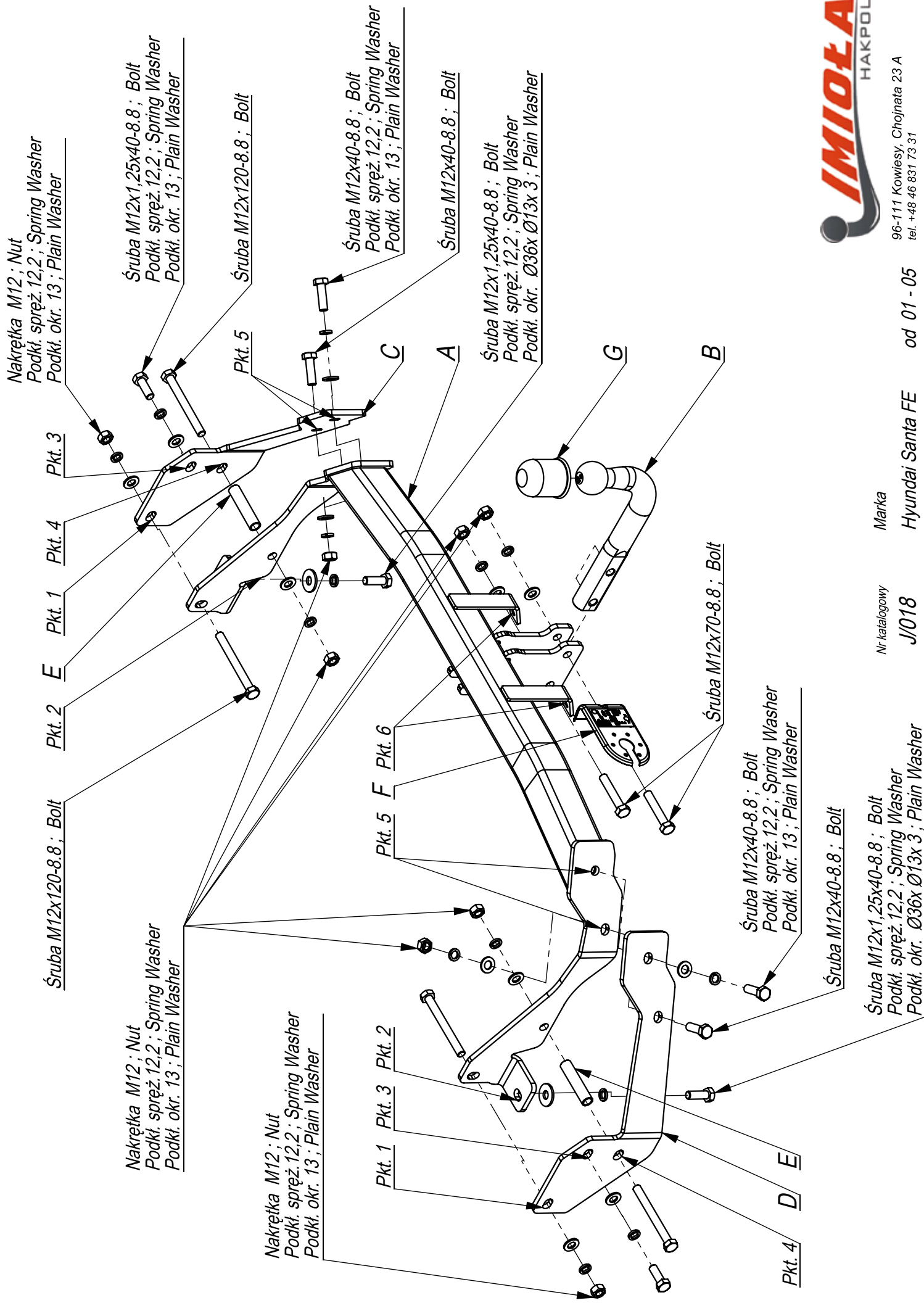

96-111 Kowiesy, Chojnata 23 A
tel. +48 46 831 73 31

Marka
Hyundai Santa FE od 01 - 05

Nr katalogowy
J/018

Śruba M12x120-8.8; Bolt
Podkł. spręż. 12,2; Spring Washer
Podkł. okr. 13; Plain Washer

Śruba M12x1,25x40-8.8; Bolt
Podkł. spręż. 12,2; Spring Washer
Podkł. okr. 13; Plain Washer

