



HYUNDAI

i10

01/2008 - 10/2013

Cat. No. J/036

E20 55R-01 3656

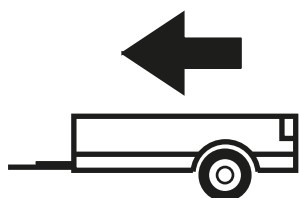

700kg

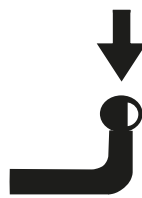

30kg

D = 5,25kN

D (kN) = $\frac{\text{MAX kg} \times \text{MAX kg}}{\text{MAX kg} + \text{MAX kg}} \times 0,00981$

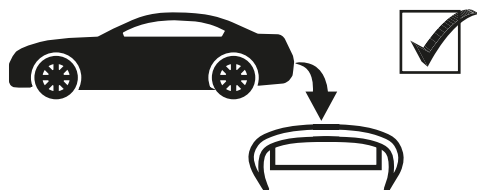

IMIOLA HAK-POL

96-111 KOWIESY, CHOJNATA 23A, POLAND

tel. +48 46 831 73 31, fax +48 831 74 29

e-mail: office@imiola.pl, www.imiola.pl

Rys. 25a

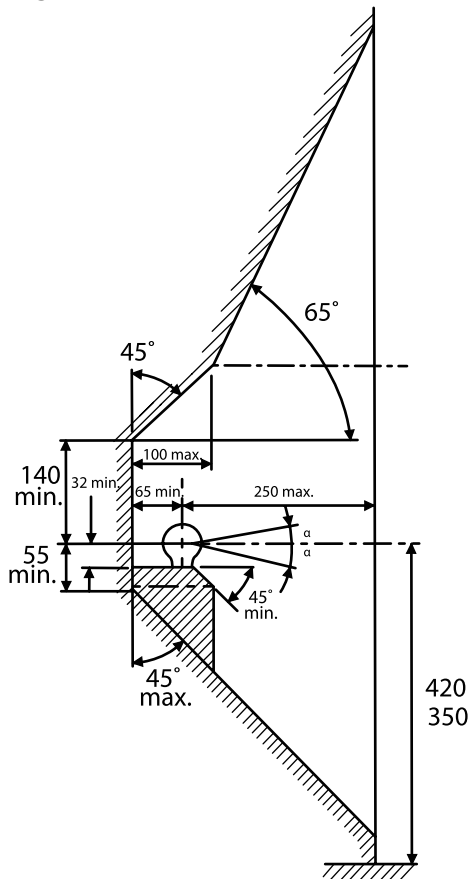

Rys. 25b

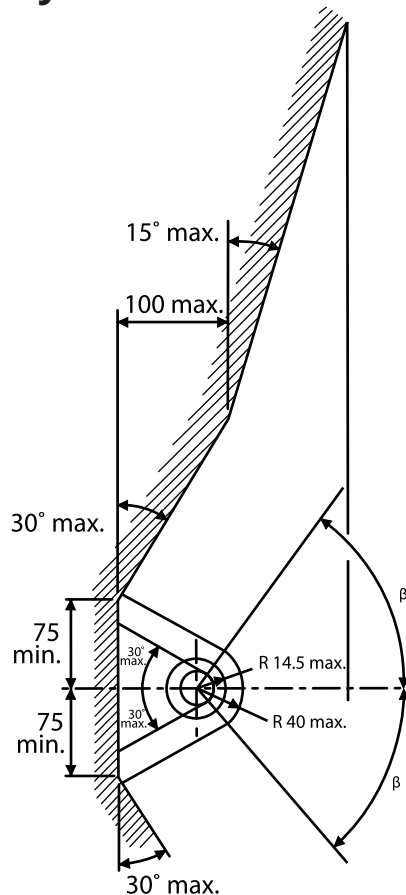

PL Należy zagwarantować przestrzeń swobodną według załącznika VII, rysunek 25a/b Regulaminu EKG ONZ 55.01 przy dopuszczalnym ciężarze całkowitym pojazdu.

FR L'espace libre doit être garanti conformément à l'annexe VII, illustration de la réglementation 55.01 CE pour un poids total en charge autorisé du véhicule.

GB The clearance specified in appendix VII, diagram 25a/b of Regulation No. 55.01 UN/EU must be guaranteed at laden weight of the vehicle.

DE Der Freiraum nach Anhang VII, Abbildung 25a/b der Vorschriften 55.01 EG ist zu gewährleisten bei zulässigem Gesamtgewicht des Fahrzeuges.

Moment skręcający dla śrub i nakrętek (8.8) Torque settings for nuts and bolts (8.8)	
M8	25Nm
M10	55Nm
M12	85Nm
M14	135Nm
M16	195Nm

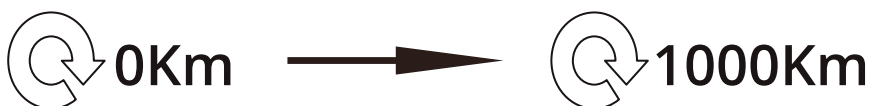

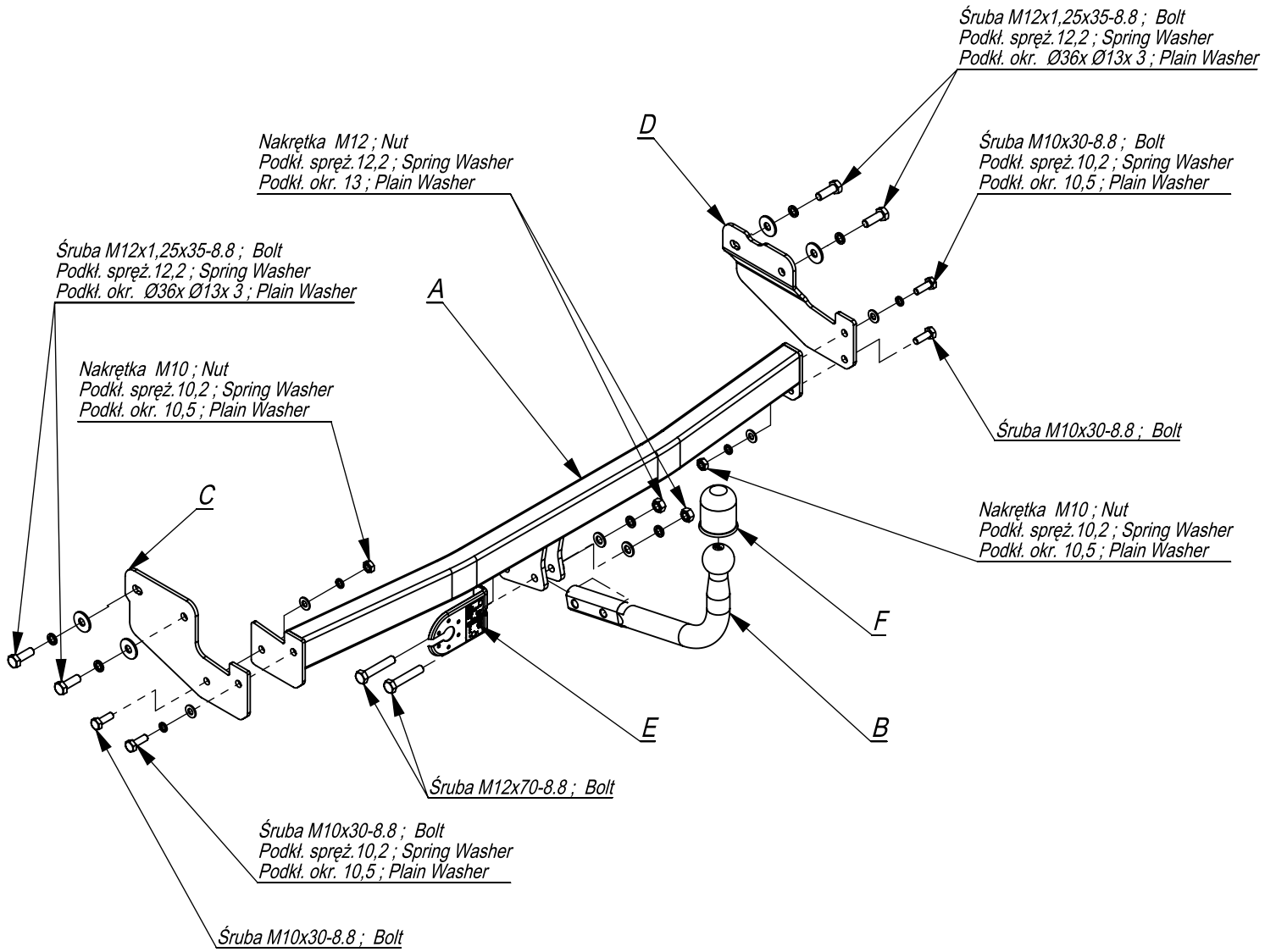

	A	x1		M12x70	2
				M12x1,25x35	4
				M10x30	4
	B	x1		M12	2
				M10	2
	C	x1		Ø36xØ13x3	4
	D	x1			13
				10,5	4
	E	x1		12,2	6
				10,2	4
	F	x1			

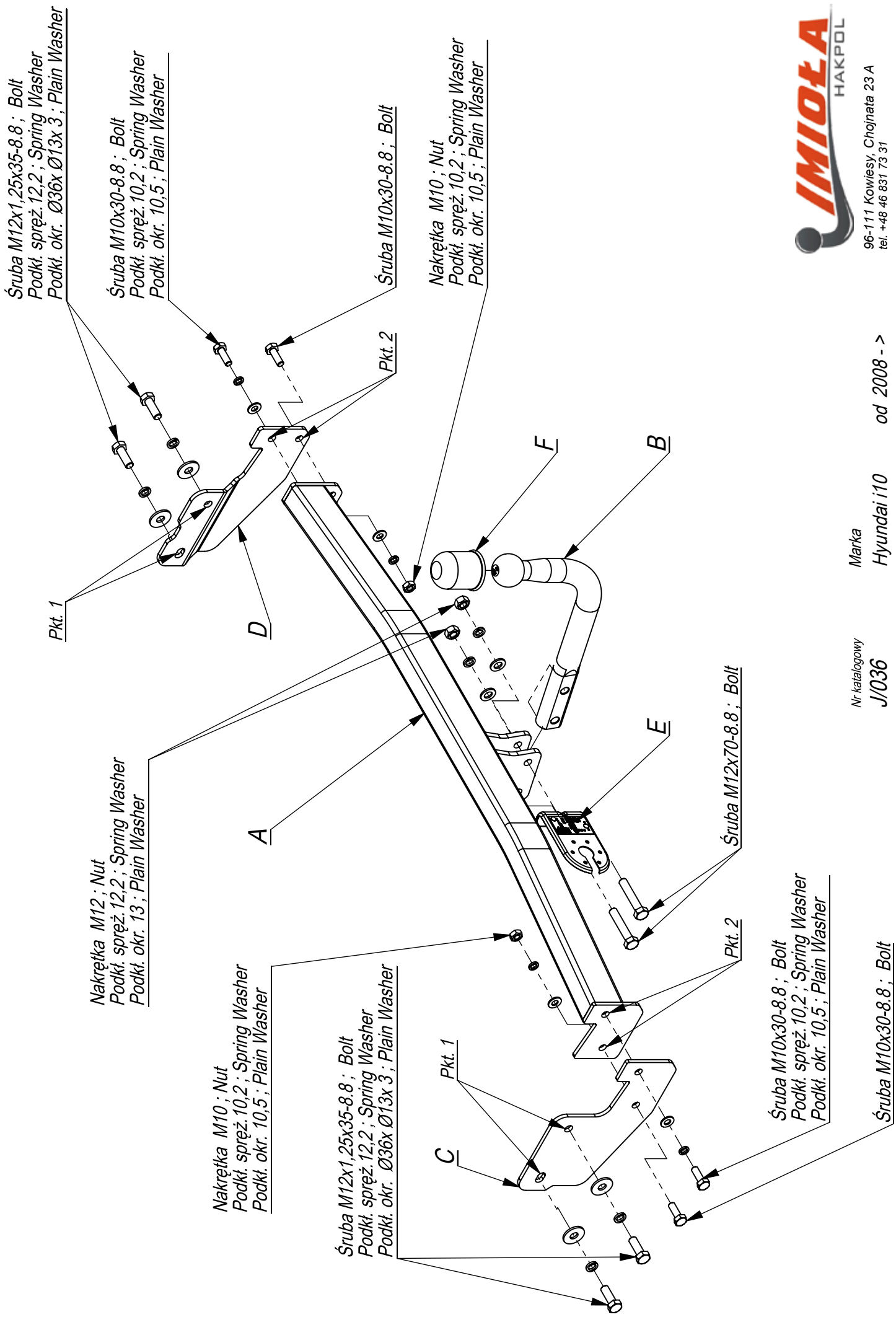

96-111 Kowiesy, Chojnata 23 A
 tel. +48 46 831 73 31

Marka
 Hyundai i10 od 2008 - >

Nr katalogowy
 J/036

