



MERCEDES
E Klasa
S211 (excl. AMG)

2003 -

Cat. No. M/A41

E20 55R-01 5194

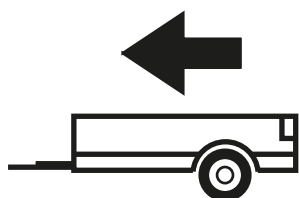

2 100kg

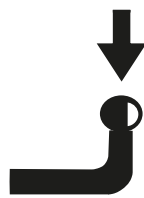

130kg

D = 11,40kN

D (kN) =



MAX kg

x

MAX kg

x 0,00981



MAX kg

+

MAX kg



IMIOLA HAK-POL

96-111 KOWIESY, CHOJNATA 23A, POLAND

tel. +48 46 831 73 31, fax +48 831 74 29

e-mail: office@imiola.pl, www.imiola.pl

Rys. 25a

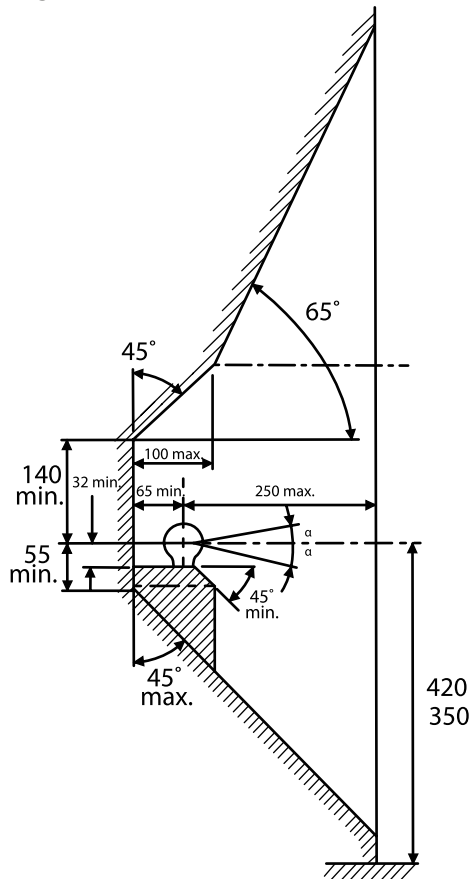

Rys. 25b

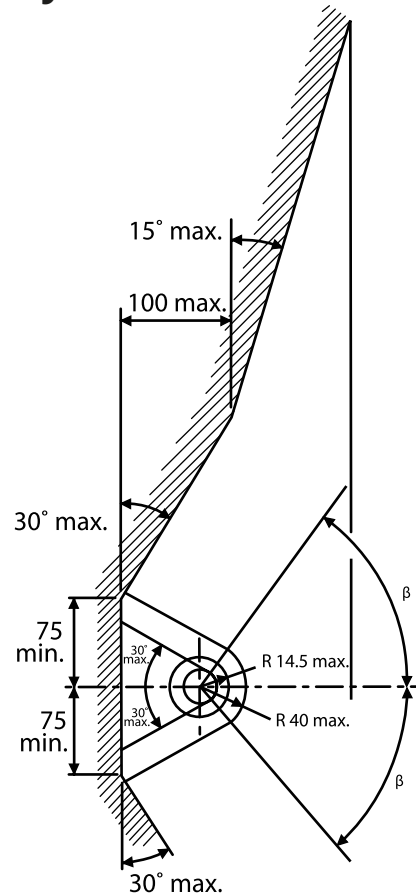

PL Należy zagwarantować przestrzeń swobodną według załącznika VII, rysunek 25a/b Regulaminu EKG ONZ 55.01 przy dopuszczalnym ciężarze całkowitym pojazdu.

FR L'espace libre doit être garanti conformément à l'annexe VII, illustration de la réglementation 55.01 CE pour un poids total en charge autorisé du véhicule.

GB The clearance specified in appendix VII, diagram 25a/b of Regulation No. 55.01 UN/EU must be guaranteed at laden weight of the vehicle.

DE Der Freiraum nach Anhang VII, Abbildung 25a/b der Vorschriften 55.01 EG ist zu gewährleisten bei zulässigem Gesamtgewicht des Fahrzeuges.

Moment skręcający dla śrub i nakrętek (8.8) Torgue settings for nuts and bolts (8.8)	
M8	25Nm
M10	55Nm
M12	85Nm
M14	135Nm
M16	195Nm

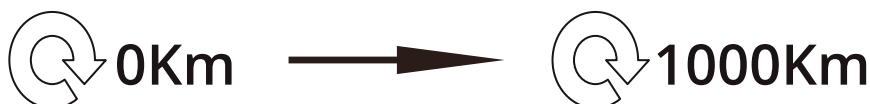

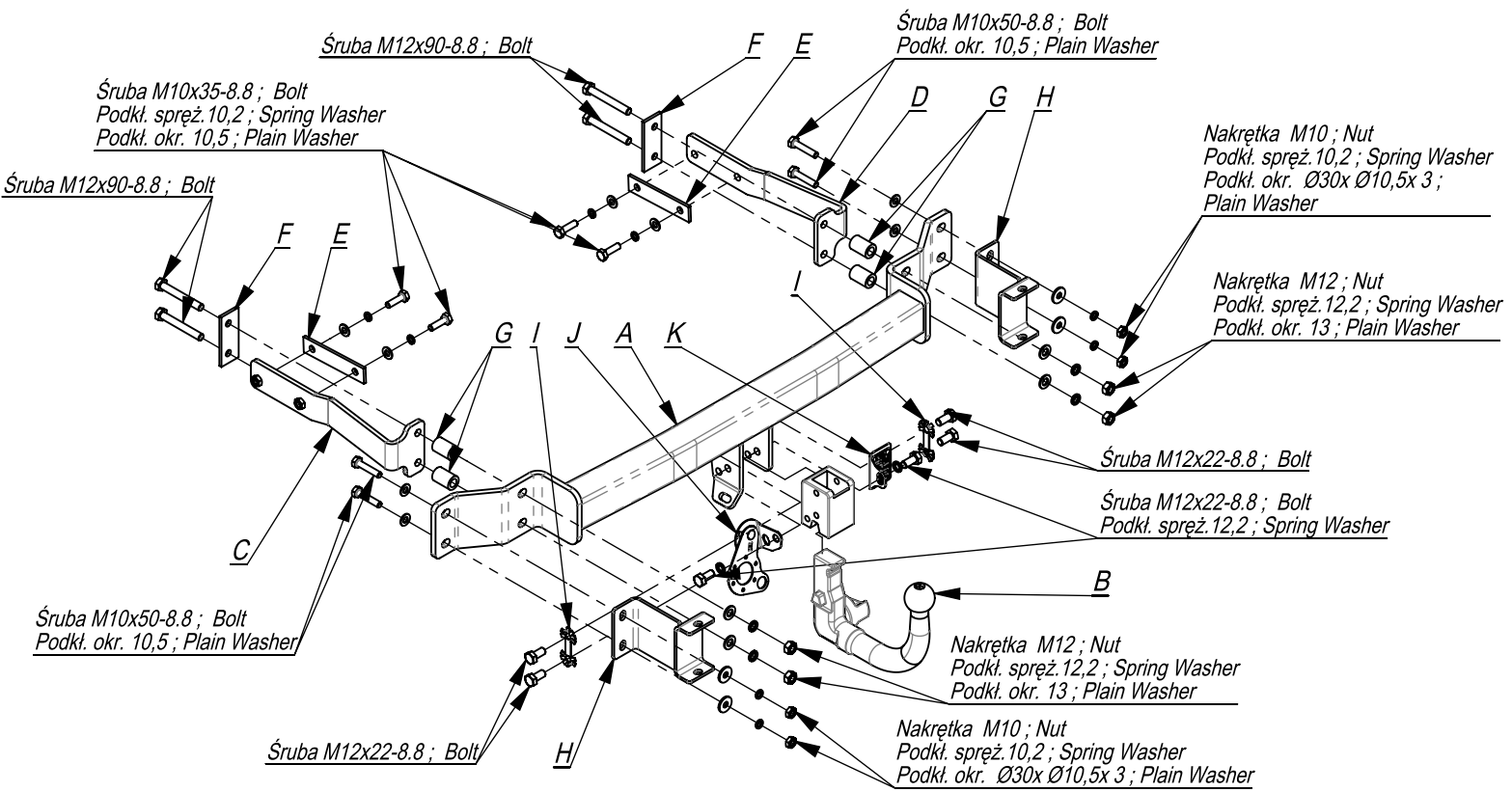

	A	x1		M12x90	4
				M12x22	6
				M10x50	4
				M10x35	4
	B	x1		M12	4
				M10	4
	C	x1		Ø30xØ10,5x3	4
	D	x1		13	4
	E	x2		10,5	8
	F	x2		12,2	6
	F	x2		10,2	8
	G	x4			
	H	x2			
	I	x2			
	J	x1			
	K	x1			

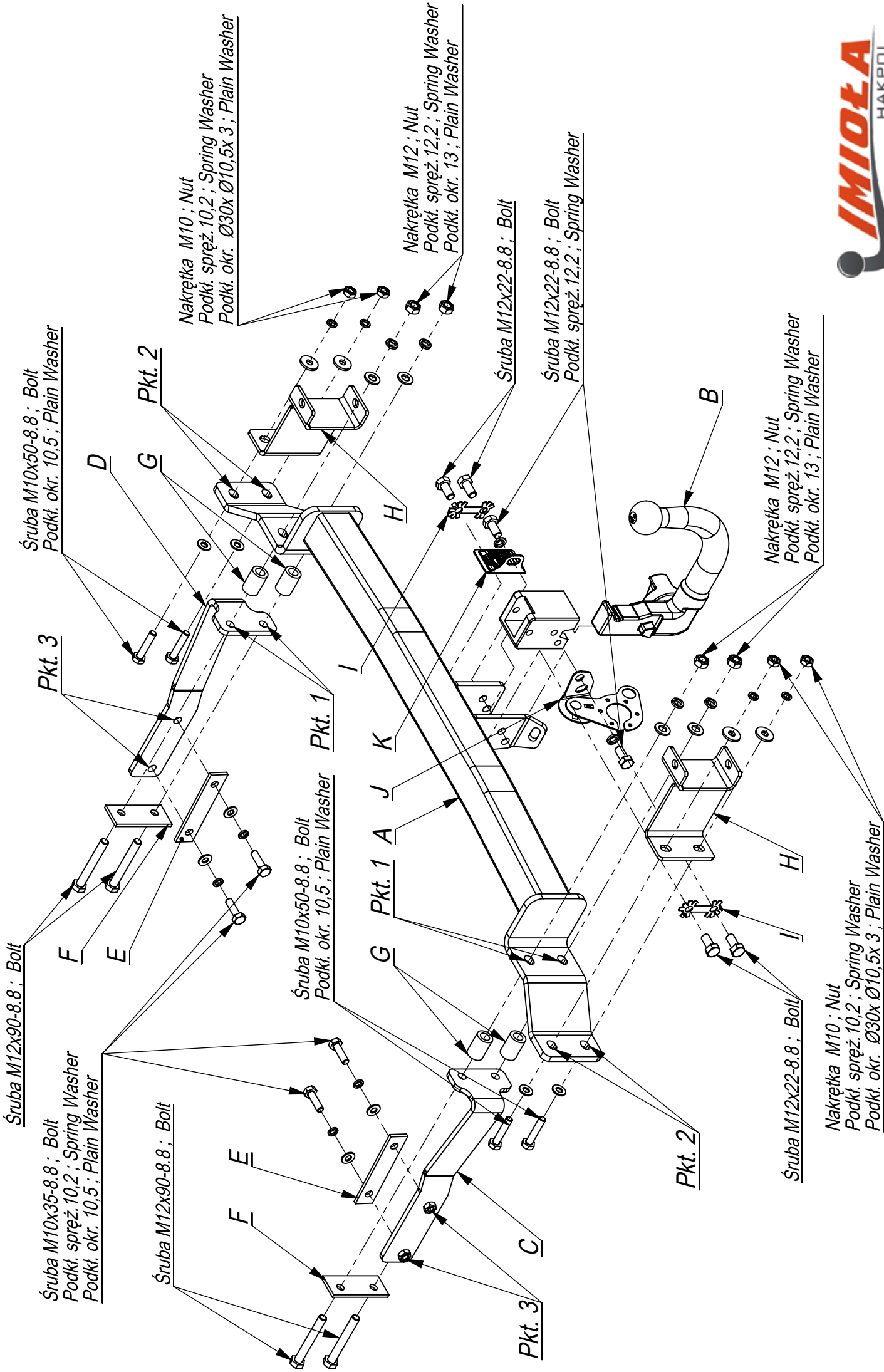

96-111 Kowiesy, Chojnata 23 A
 tel. +48 46 831 73 31

Nr katalogowy M/A41
 Marka Mercedes E-Series S-211 (excl.AMG)
 od 03 ->

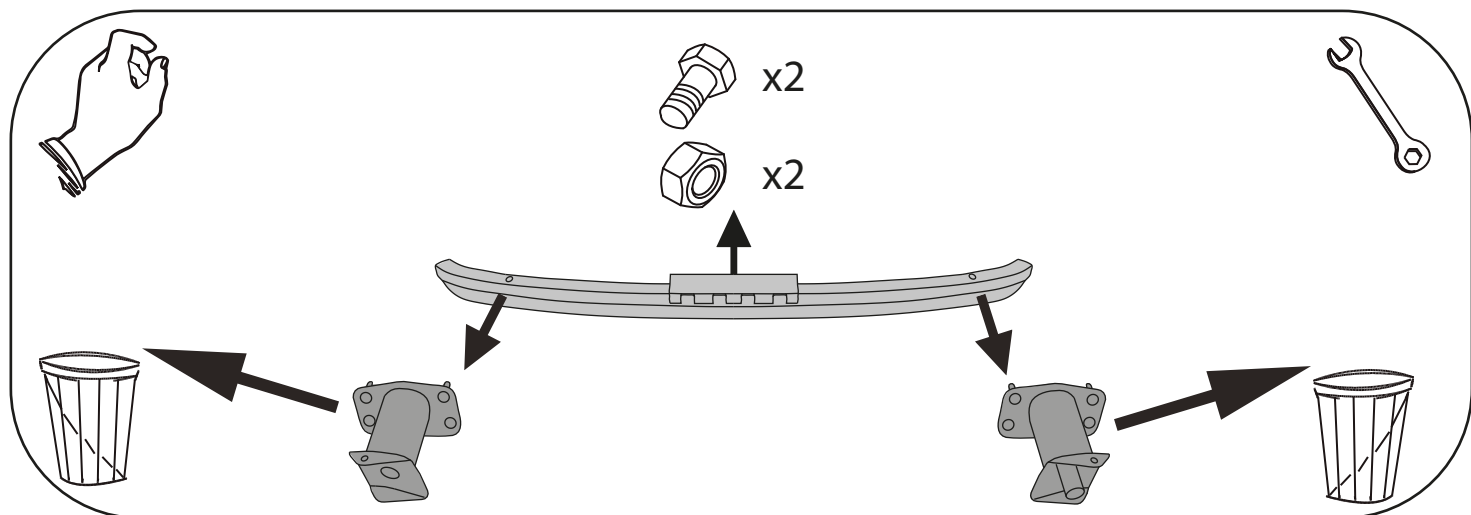
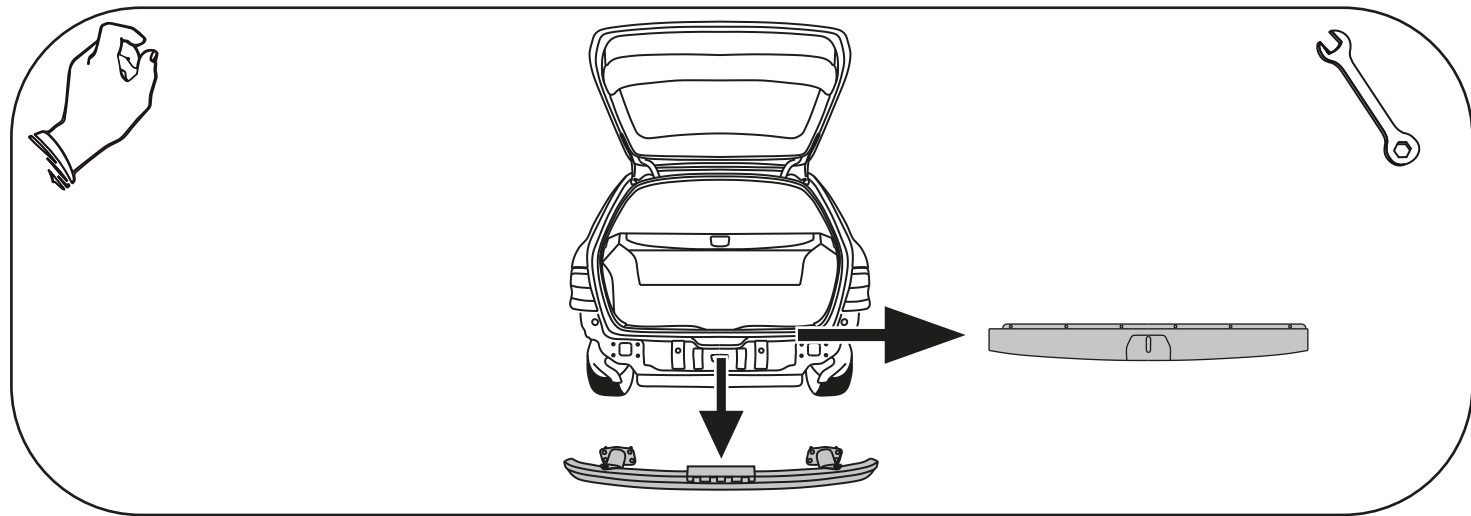
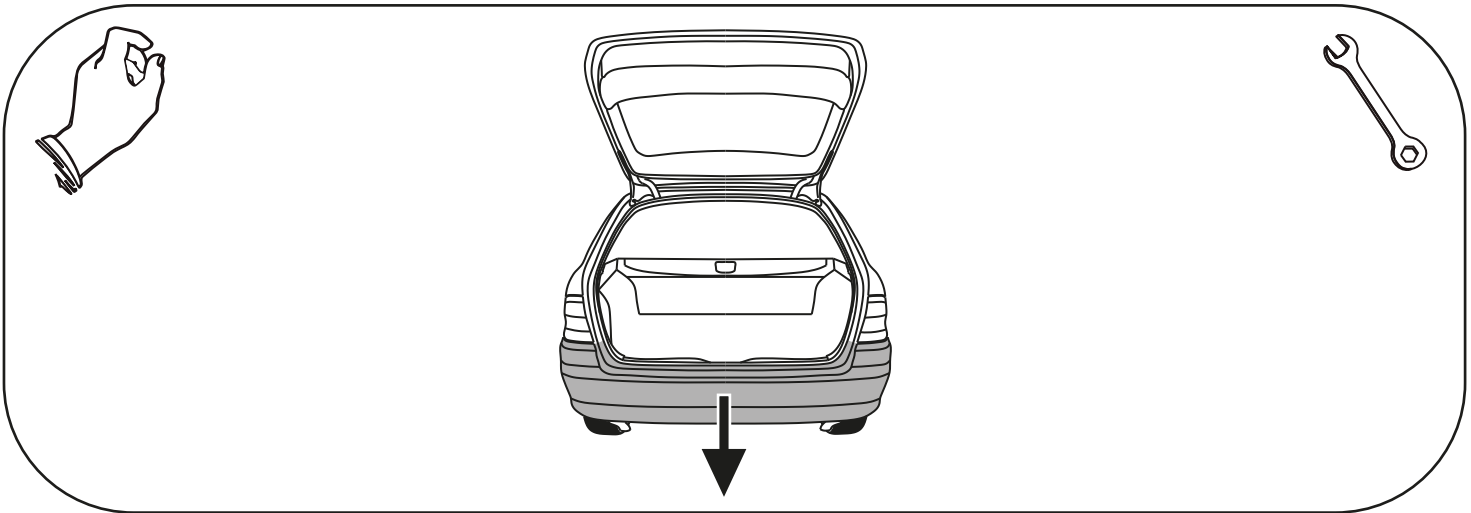
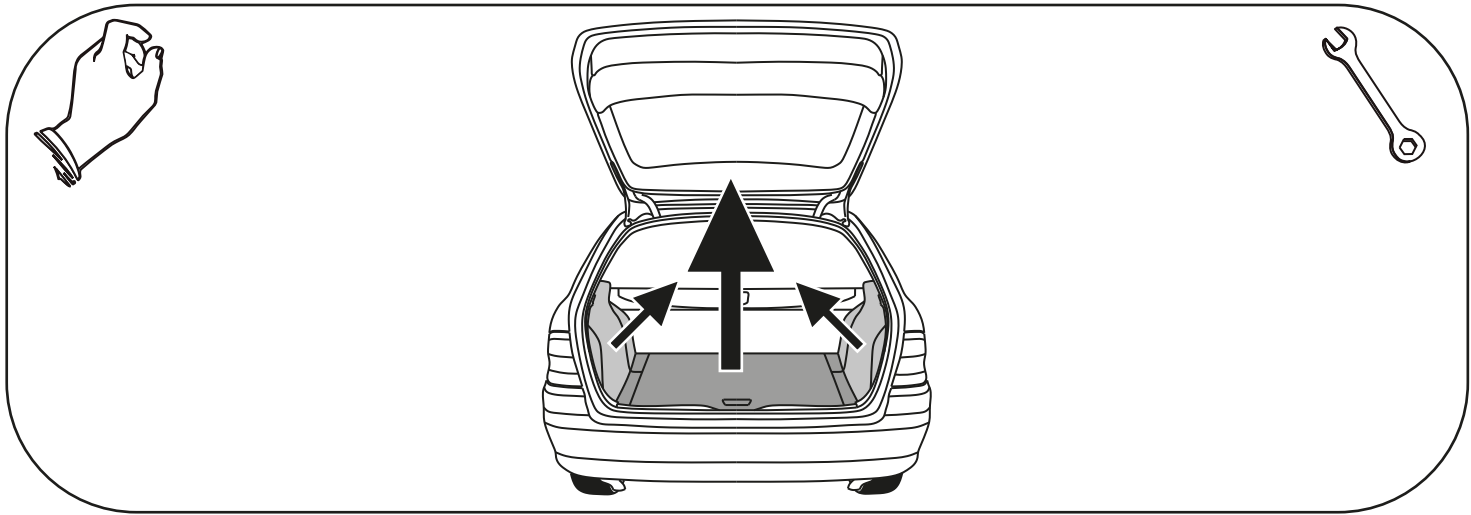

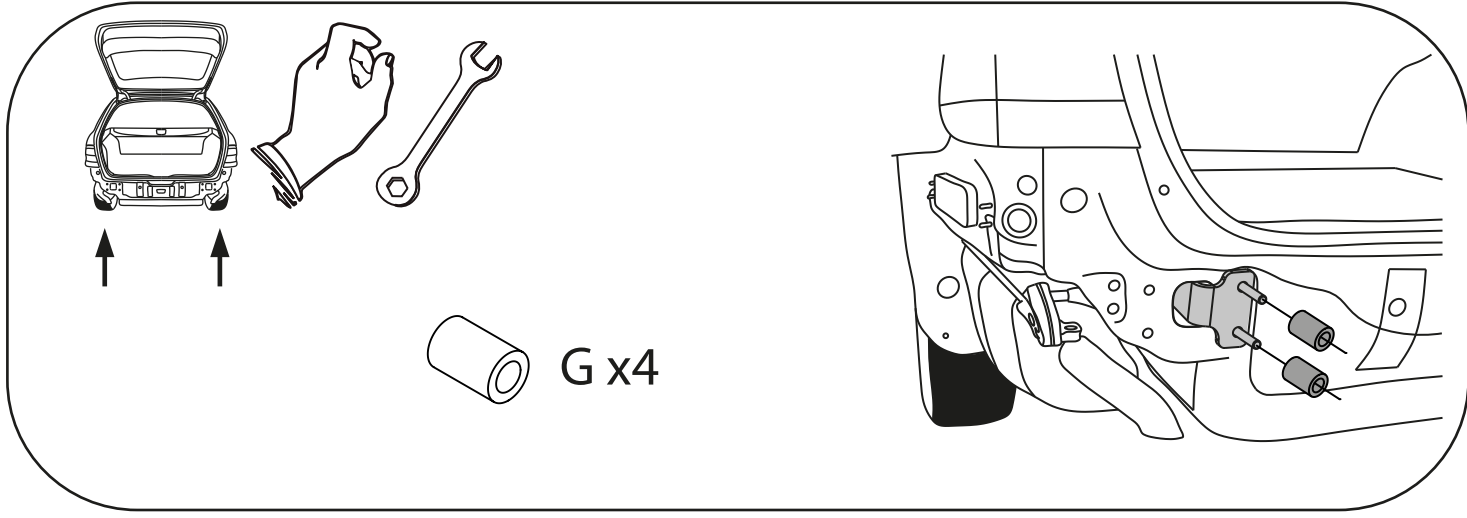
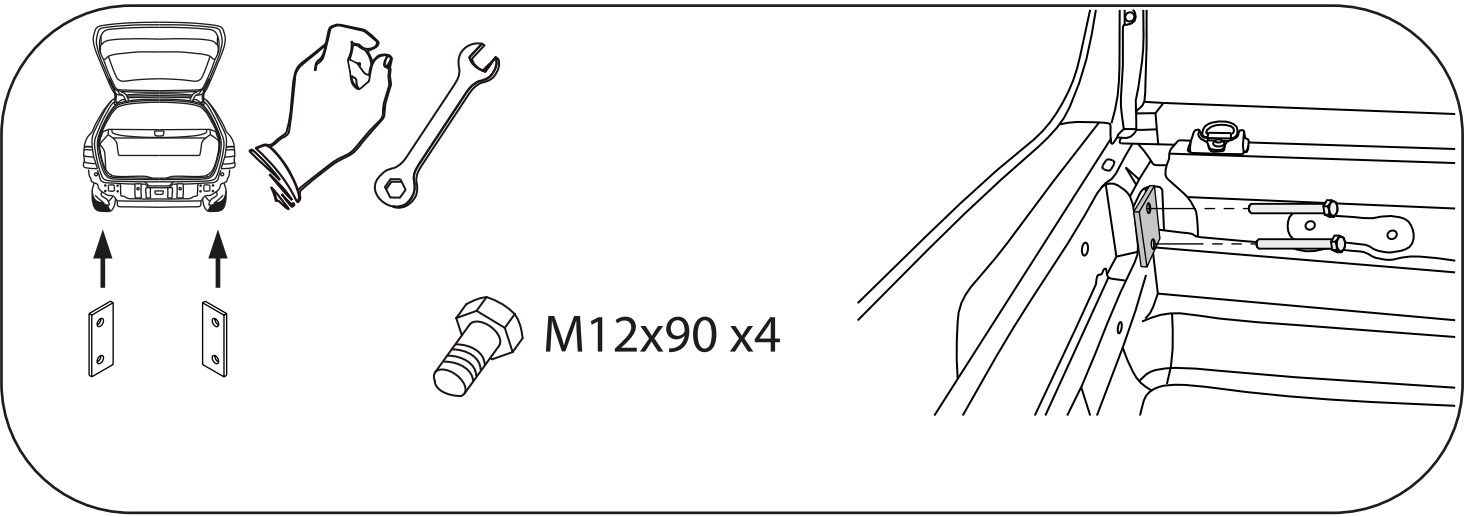
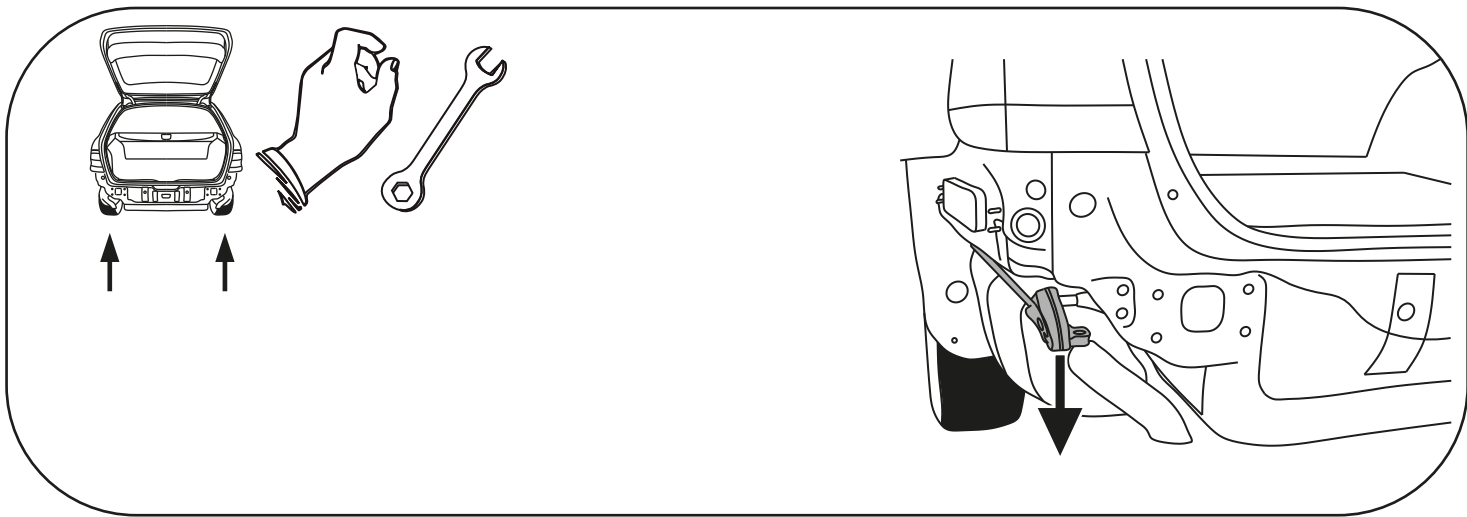

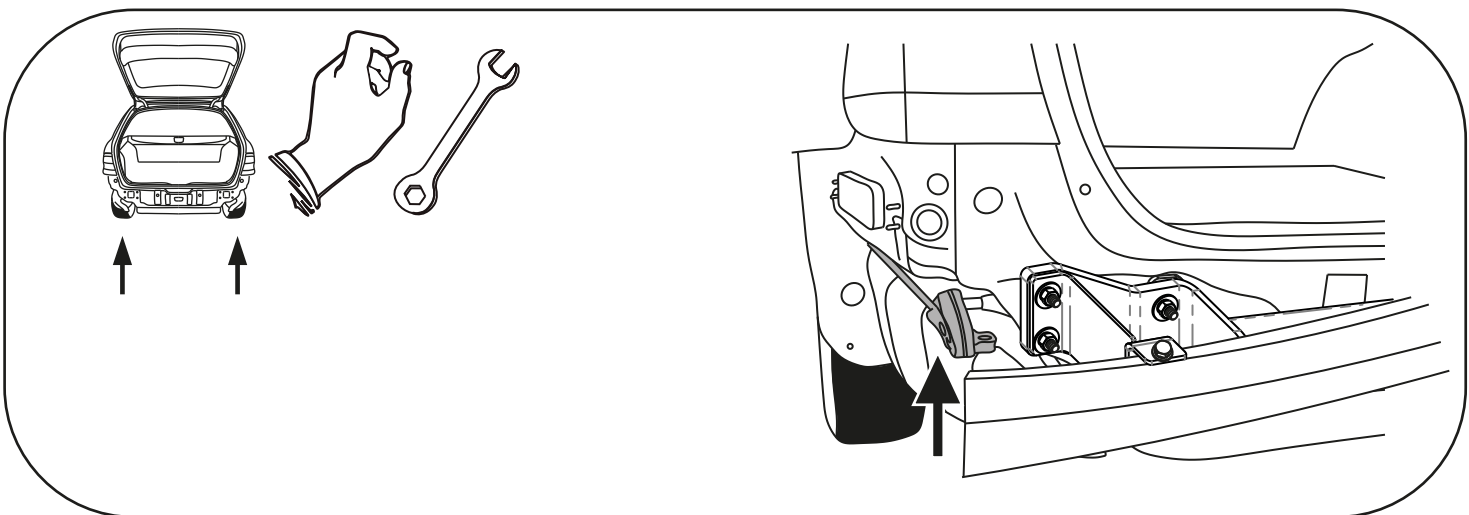
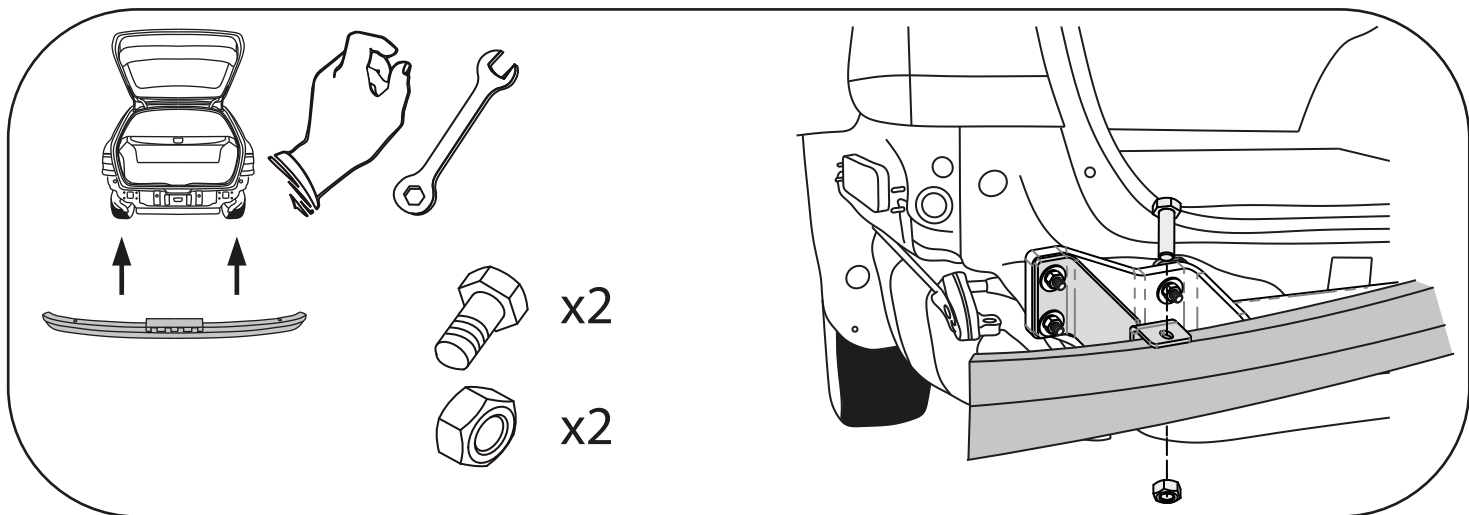
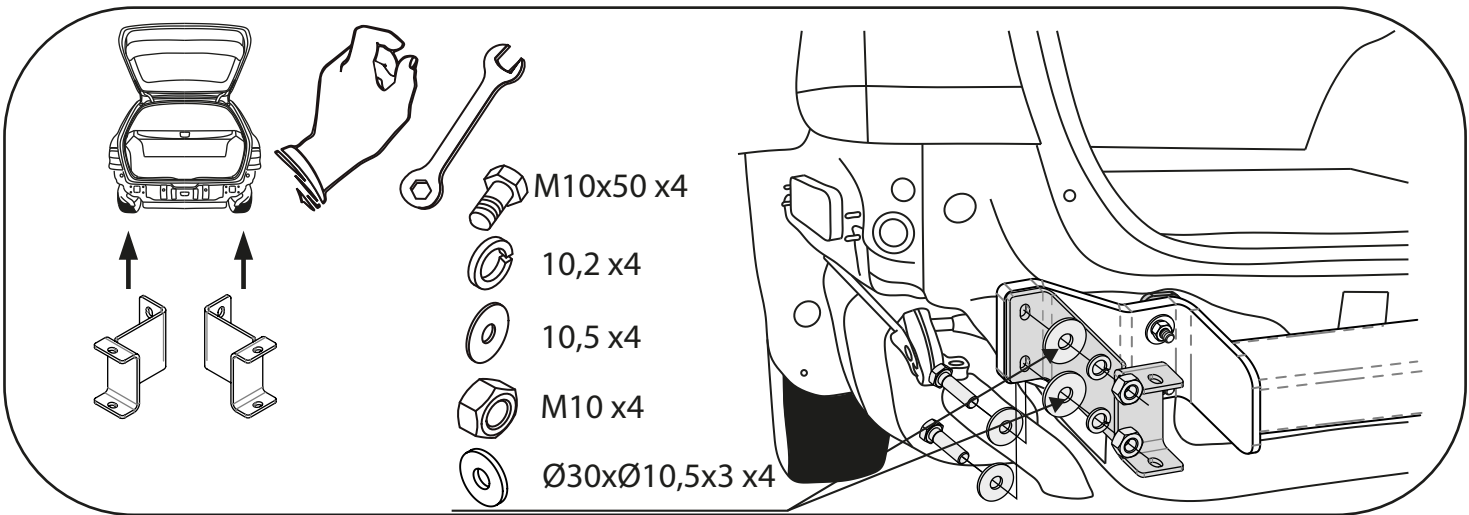
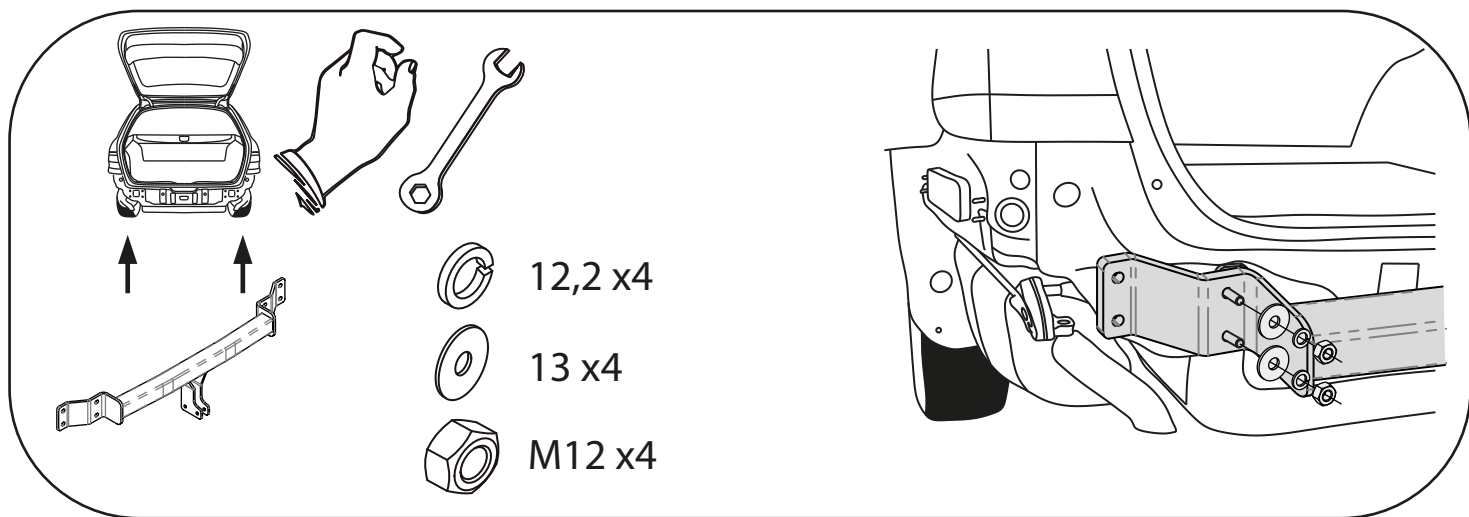

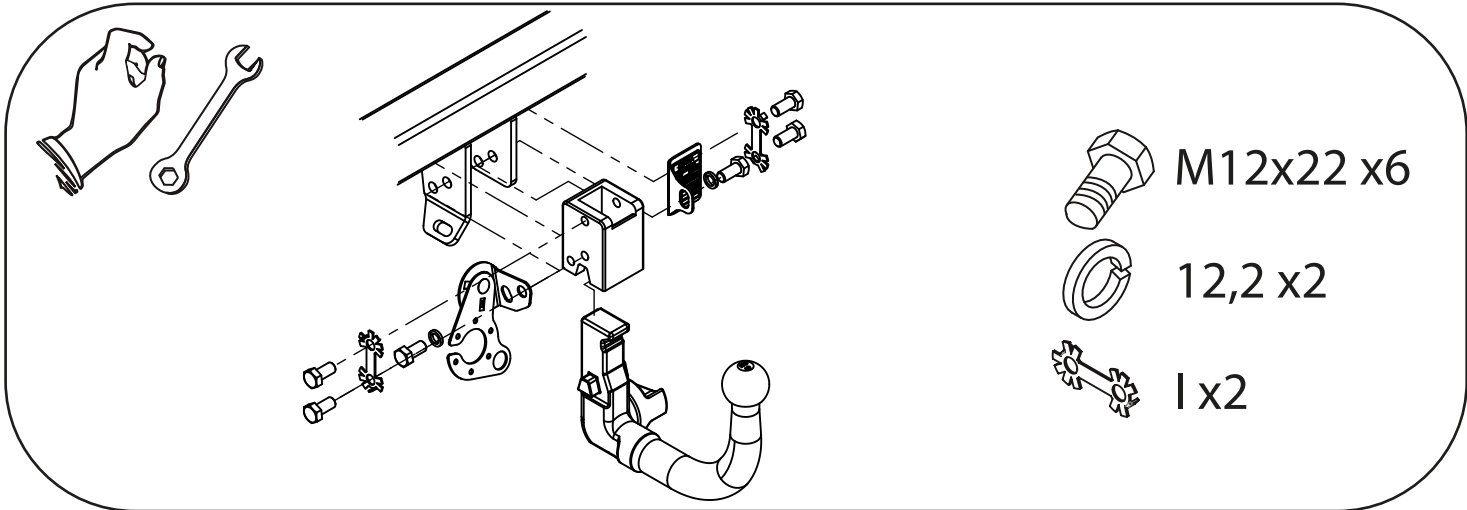
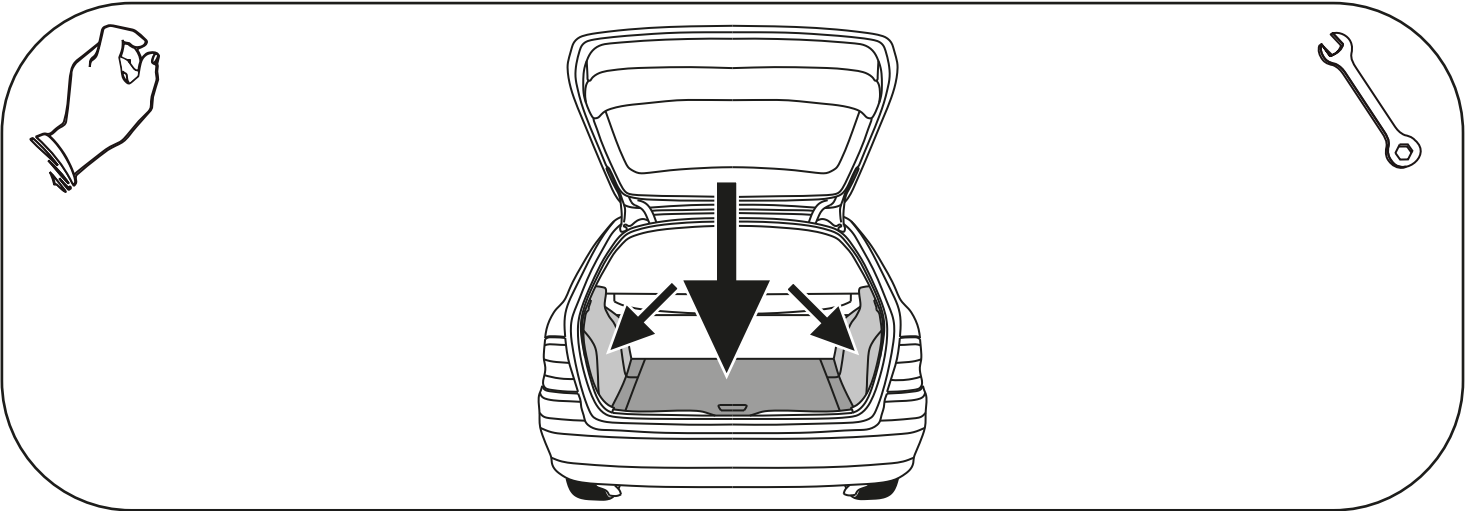
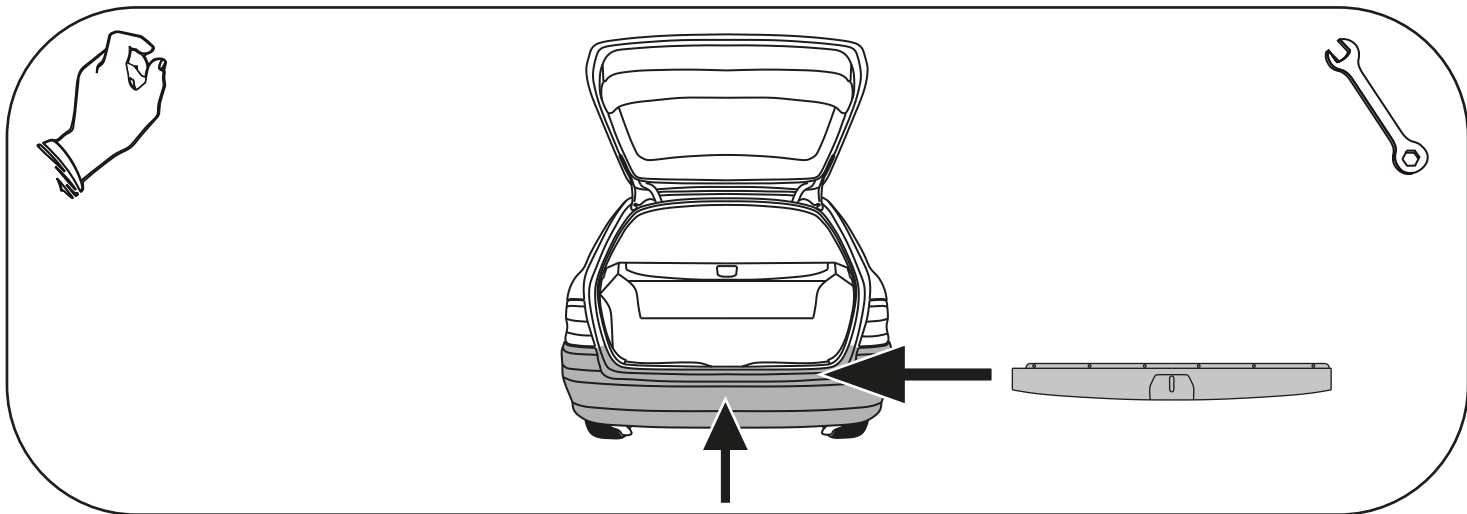



!
CRIMP

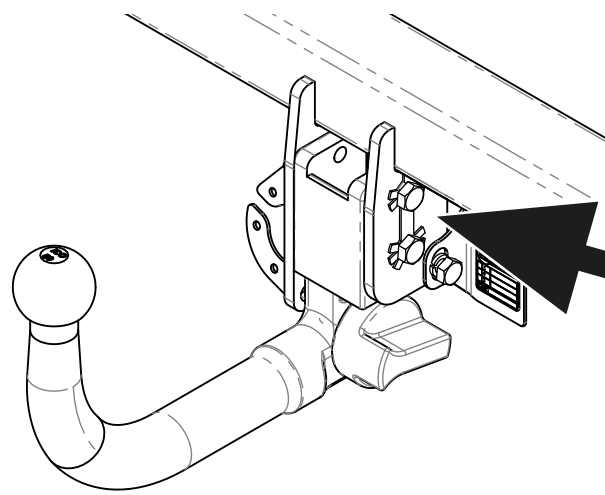
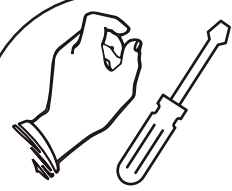
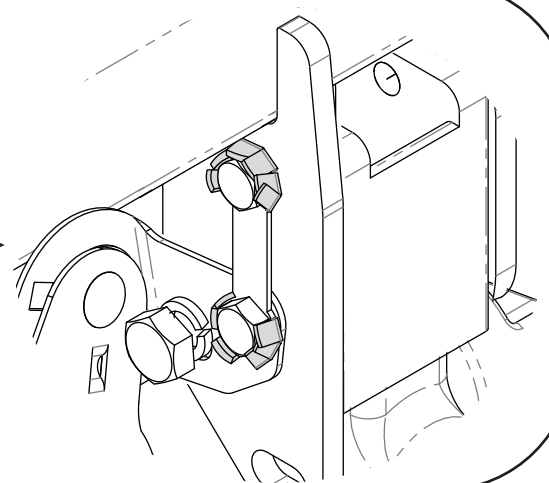
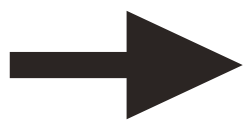
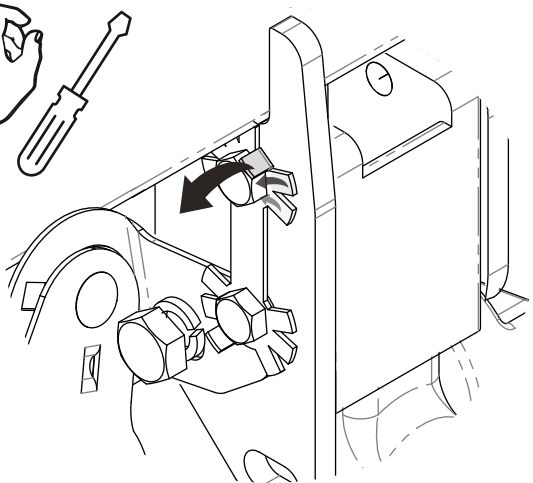
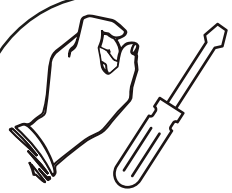
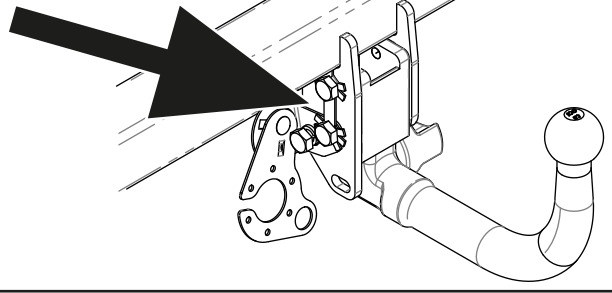

!
CRIMP

