



MERCEDES GLA (X156)
 MERCEDES CLA (C117)

2014 -
 04/2013 -

Cat. No. **M/A49**

E20 E20 55R-01 5015

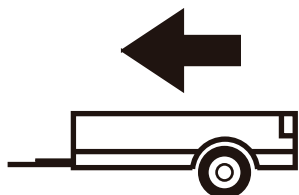

1800kg

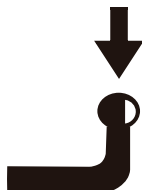

100kg

D = 9,52kN

D (kN) =



MAX kg x MAX kg

x 0,00981



MAX kg + MAX kg

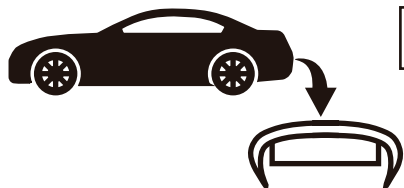

IMIOLA HAK-POL

96-111 KOWIESY, CHOJNATA 23A, POLAND

Tel. + 48 46 831 73 31, fax +48 831 74 29

e-mail: office@imiola.pl, www.imiola.pl

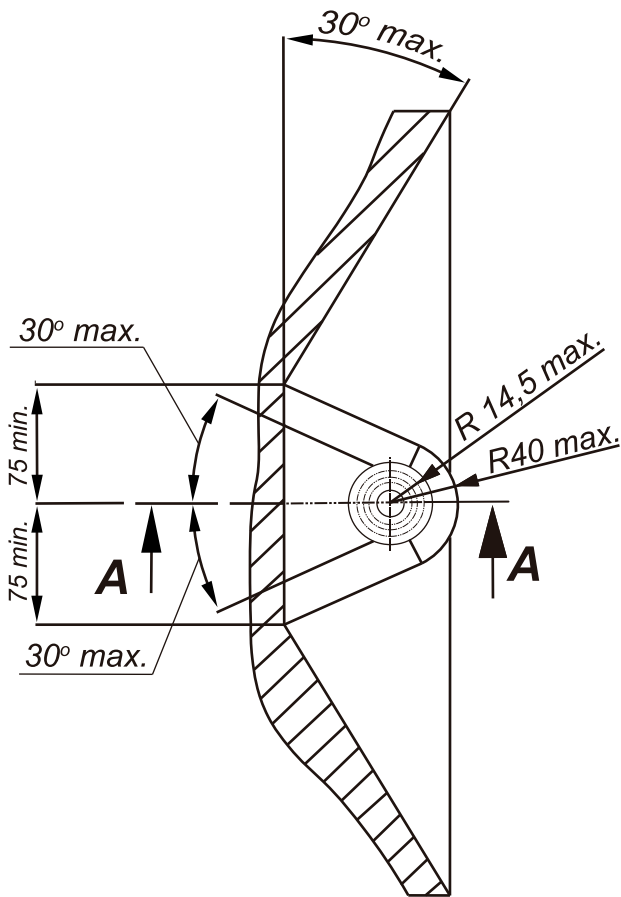

PRZEKRÓJ A-A

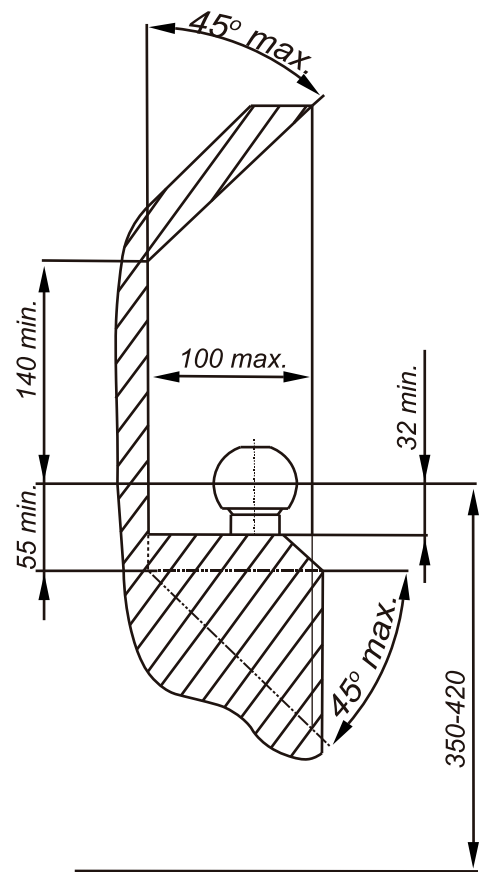

PL Należy zagwarantować przestrzeń swobodną według załącznika VII, rysunek 25a/b Regulaminu EKG ONZ 55.01 przy dopuszczalnym ciężarze całkowitym pojazdu.

F L'espace libre doit être garanti conformément à l'annexe VII, illustration de la réglementation 55.01 CE pour un poids total en charge autorisé du véhicule.

GB The clearance specified in appendix VII, diagram 25a/b of Regulation No. 55.01 UN EU must be guaranteed at laden weight of the vehicle.

D Der Freiraum nach Anhang VII, Abbildung 25a/b der Vorschriften 55.01 EG ist zu gewährleisten bei zulässigem Gesamtgewicht des Fahrzeuges.

Moment skręcający dla śrub i nakrętek (8.8) Torque settings for nuts and bolts (8.8)	
M8	25Nm
M10	55Nm
M12	85Nm
M14	135Nm
M16	195Nm

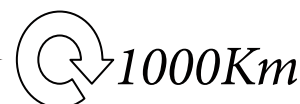

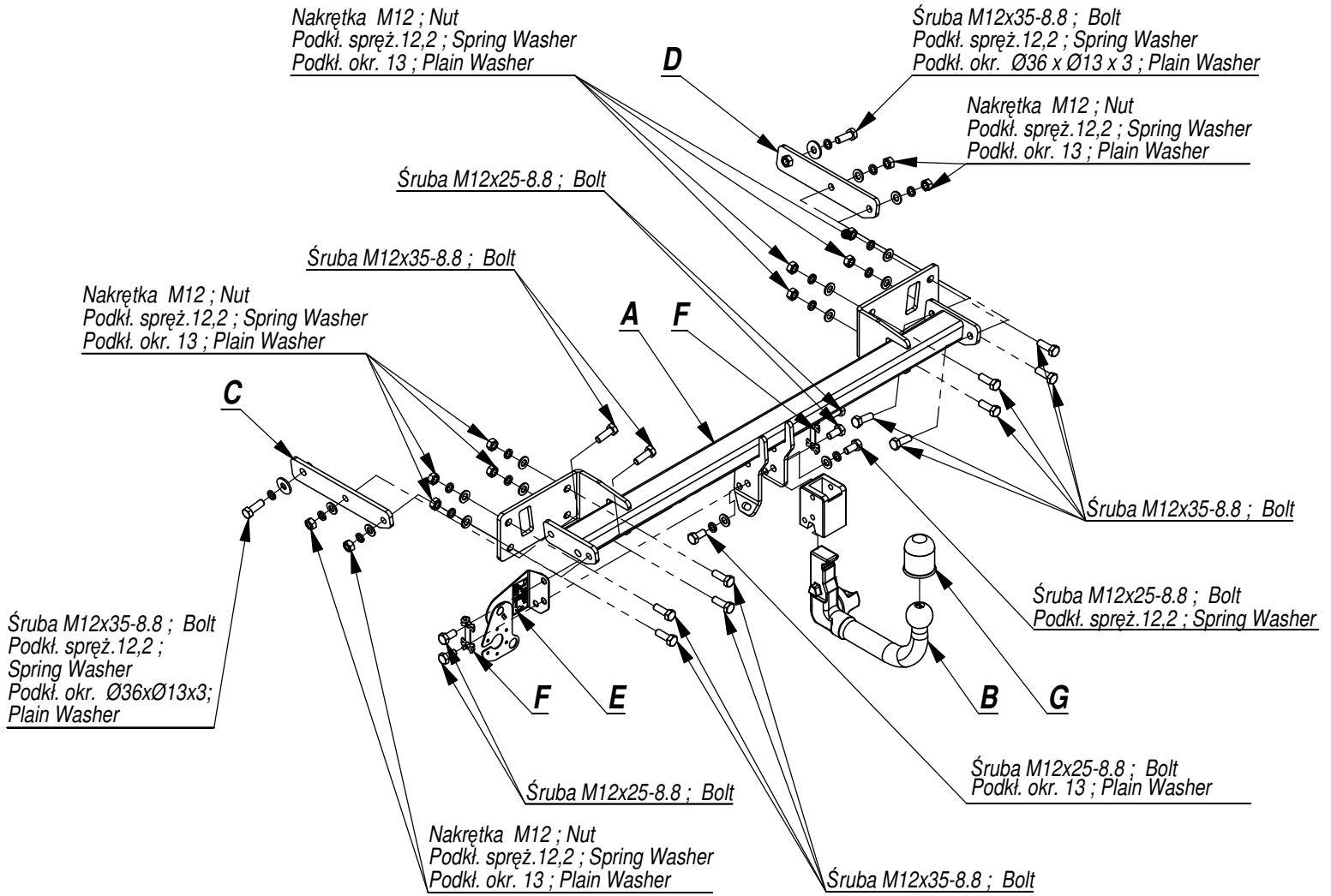

	A	x1		M12x35	14
				M12x25	6
	B	x1		M12	14
	C	x1		Ø36xØ13x3	2
	D	x1		13	12
	E	x1		12,2	16
	F	x1			

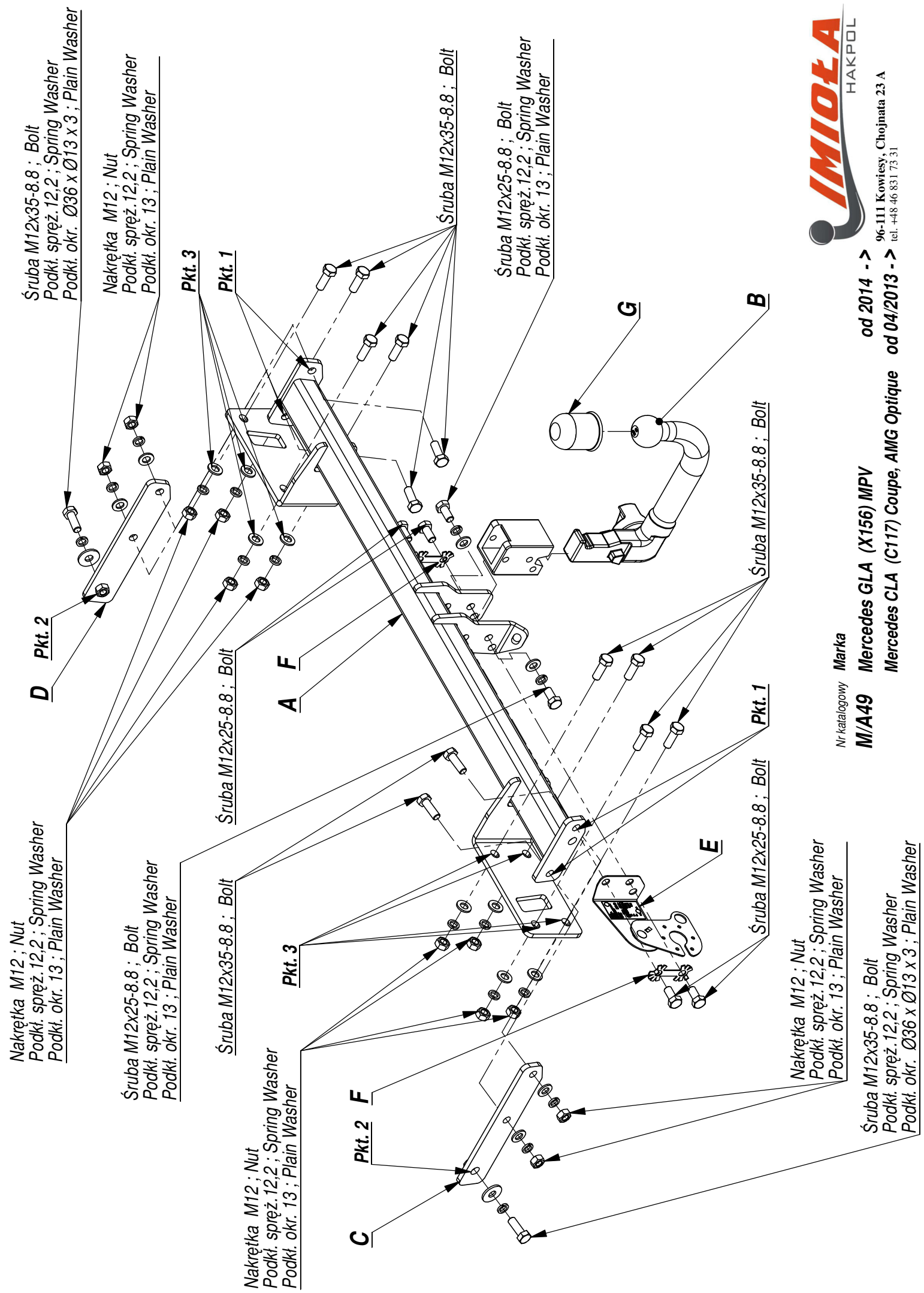

Nr katalogowy **M/A49** Marka **Mercedes GLA (X156) MPV** od 2014 ->
Mercedes CLA (C117) Coupe, AMG Optique od 04/2013 ->

96-111 Kowiesy, Chojnata 23 A
 tel. +48 46 831 73 31

Nakrętka M12 ; Nut
 Podkł. spręż.12,2 ; Spring Washer
 Podkł. okr. 13 ; Plain Washer

Śruba M12x35-8.8 ; Bolt
 Podkł. spręż.12,2 ; Spring Washer
 Podkł. okr. 13 ; Plain Washer

- Odkręcić lampy i zderzak .
- Odkręcić belkę zderzeniową (nie będzie już wykorzystana).
- Opuścić tłumik z zawiesia.
- Belkę haka A przykręcić tylnego pasa lekko śrubami M12x35 8.8 (pkt3).
- Elementy C i D wsunąć w podłużnice lekko przykręcając śrubami M12x35 (pkt2).
- Następnie skręcić elementy C i D z belką haka A śrubami M12x35 8.8 (pkt1).
- Dokręcić wszystkie śruby z momentem według tabeli.
- Przykręcić tłumik.
- Założyć zderzak i lampy.
- Dokręcić kulę i blachę gniazda elektrycznego śrubami M12x25 8.8.
- Podłączyć instalację elektryczną.

- Unscrew the lamps and bumper.
- Unscrew the bumper bar (it will not be used any more).
- Lower the muer from the hanger.
- Screw the main bar A to the rear belt with bolts M12x35 8.8 (point 3).
- Insert the elements C and D into frame side members and screw slightly with bolts M12x35 8.8 (point 2).
- Screw the elements C and D to the main bar A with bolts M12x35 8.8 (point 1).
- Tighten all the bolts according to the torque setting- see the table.
- Screw the muer.
- Screw the bumper and lamps.
- Fix the ball and electric plate with bolts M12x25 8.8.
- Connect the electric wires.

- Dévisser le pare-chocs et les lampes.
- Dévisser la poutre pare-chocs de la voiture (elle ne sera plus utilisée).
- Enlever le pot d'échappement de la suspension.
- Visser la barre de crochet A à la jupe arrière légèrement avec les boulons M12x35 8.8 (point 3).
- Glisser les éléments C et D dans les longerons et les visser légèrement avec les boulons M12x35 (point 2).
- Ensuite serrer les éléments C et D avec la barre de crochet A avec les boulons M12x35 8.8 (point1).
- Serrer tous les boulons avec un couple de serrage selon tableau.
- Visser le pot d'échappement.
- Installer le pare-chocs et les lampes.
- Serrer la boule et la tôle de la prise électrique avec les boulons M12x25 8.8.
- Brancher l'installation électrique.

- Die Rückleuchten und den Stoßfänger abschrauben.
- Den Stoßträger abschrauben (wird nicht mehr benötigt)..
- Den Schalldämpfer vom Halter absenken.
- Den AHK-Querträger A am hinteren Band mit Schrauben M12x35 8.8 leicht anschrauben (Punkt 3).
- Die Bauteile C und D in die Längsträger einschieben und mit Schrauben M12x35 leicht anziehen.
- Danach die Bauteile C und D mit den AHK-Querträger A mit Schrauben M12x35 8.8 (Punkt 1) zusammenschrauben.
- Ziehen Sie alle Schrauben mit dem Drehmoment gemäß der Tabelle an.
- Den Schalldämpfer anschrauben.
- Den Stoßfänger und die Rückleuchten einsetzen.
- Schrauben Sie die Kugel und den Steckdosenblech mit den Schrauben M12x25 an.
- Die elektrische Installation anschließen.

- Desenrosque las lámparas y el parachoques.
- Desenrosque las lámparas, baje el silenciador y desatornille el protector térmico.
- Baje el silenciador de la suspensión.
- Apretar la barra del gancho A ligeramente a la correa trasera con los tornillos M12x35 8.8 (punto 3).
- Insertar los elementos C y D en los largueros atornillando ligeramente los tornillos M12x35 (punto 2).
- A continuación, jar los elementos C y D a la barra del gancho A con los tornillos M12x35 8.8 (punto 1).
- Apretar todos los tornillos con el par según la tabla anterior.
- Fijar el silenciador.
- Montar el parachoques y las luces.
- Apretar la bola y la placa de la toma eléctrica usando tornillos M12x25 8.8.
- Conectar la instalación eléctrica.

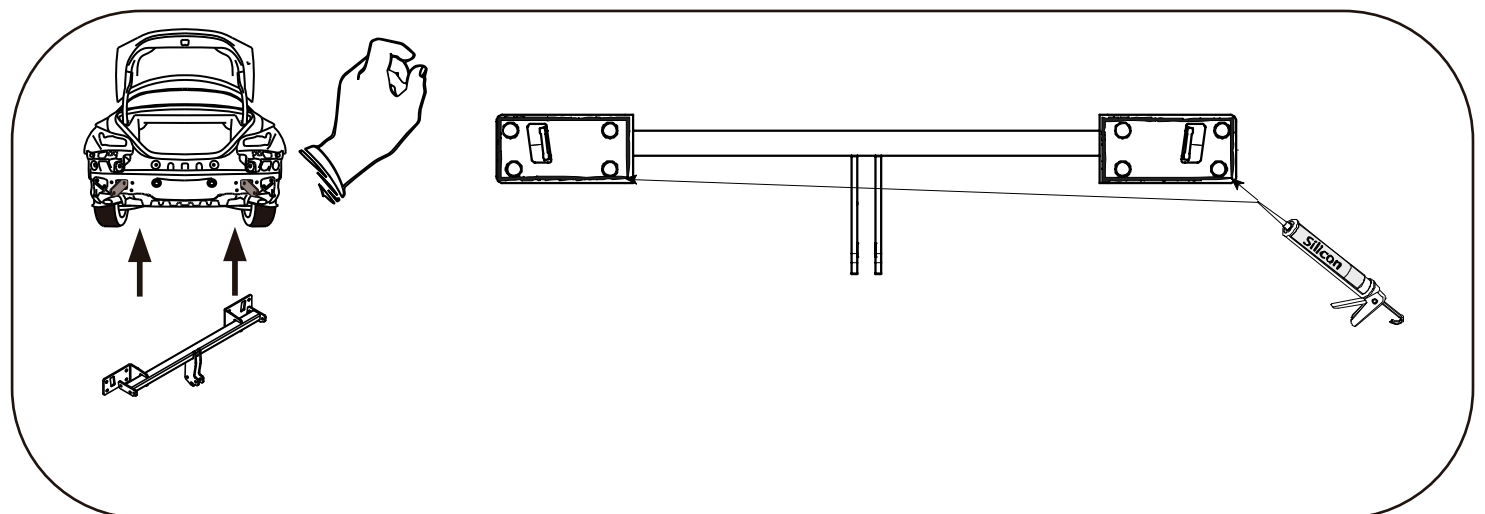
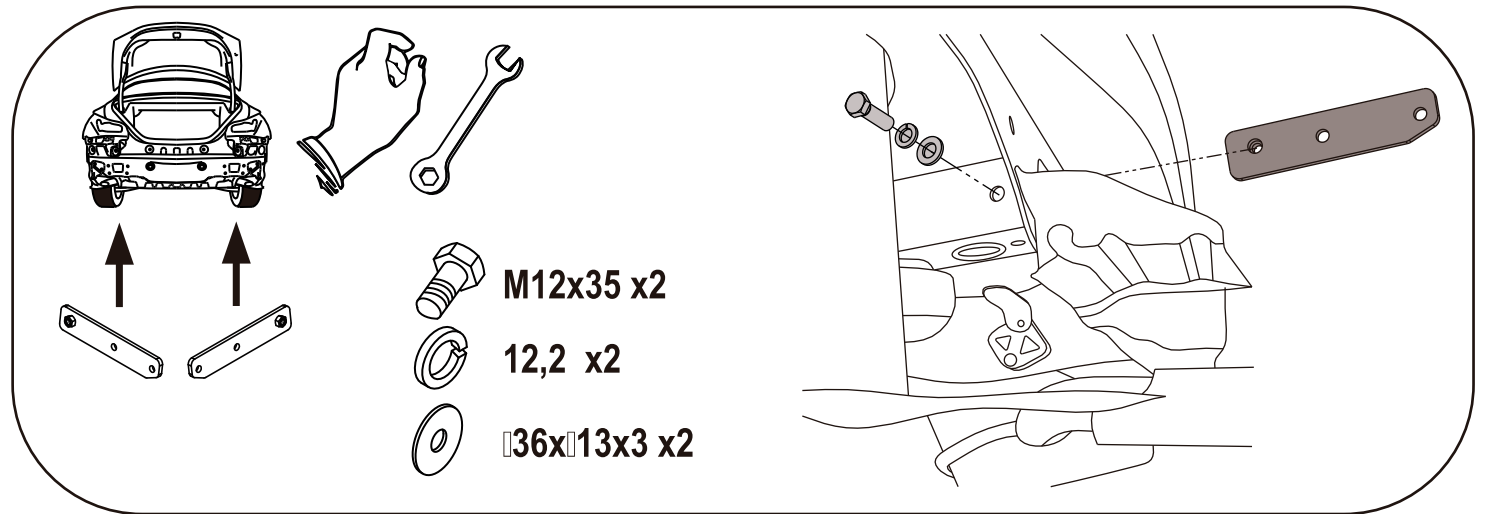
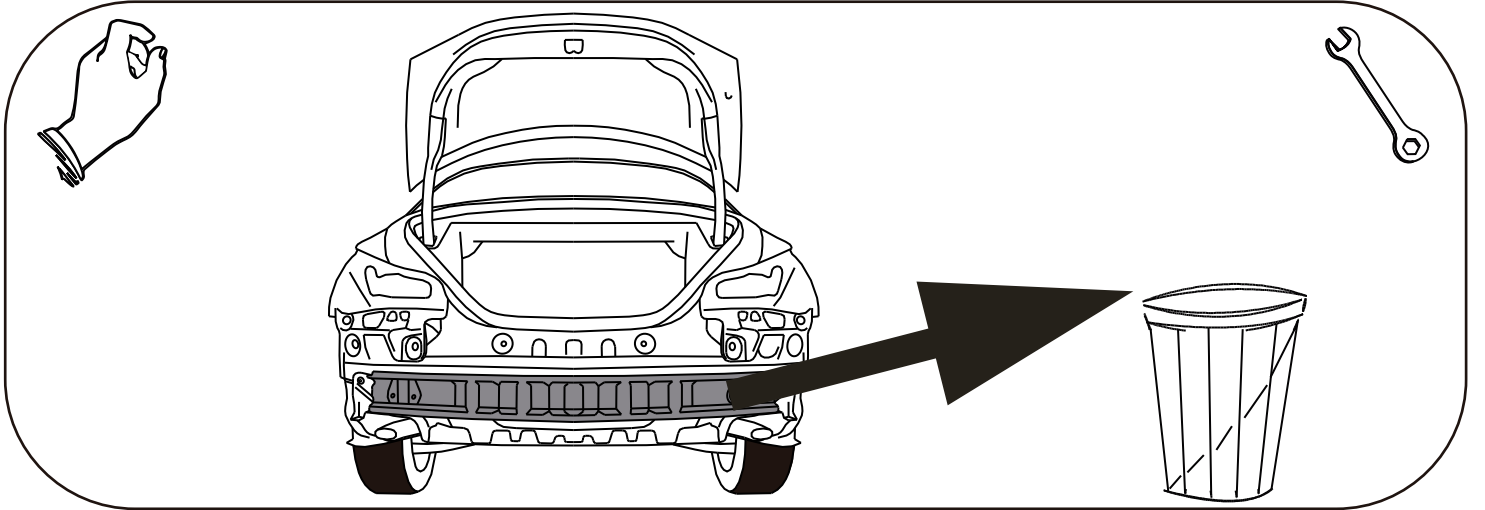
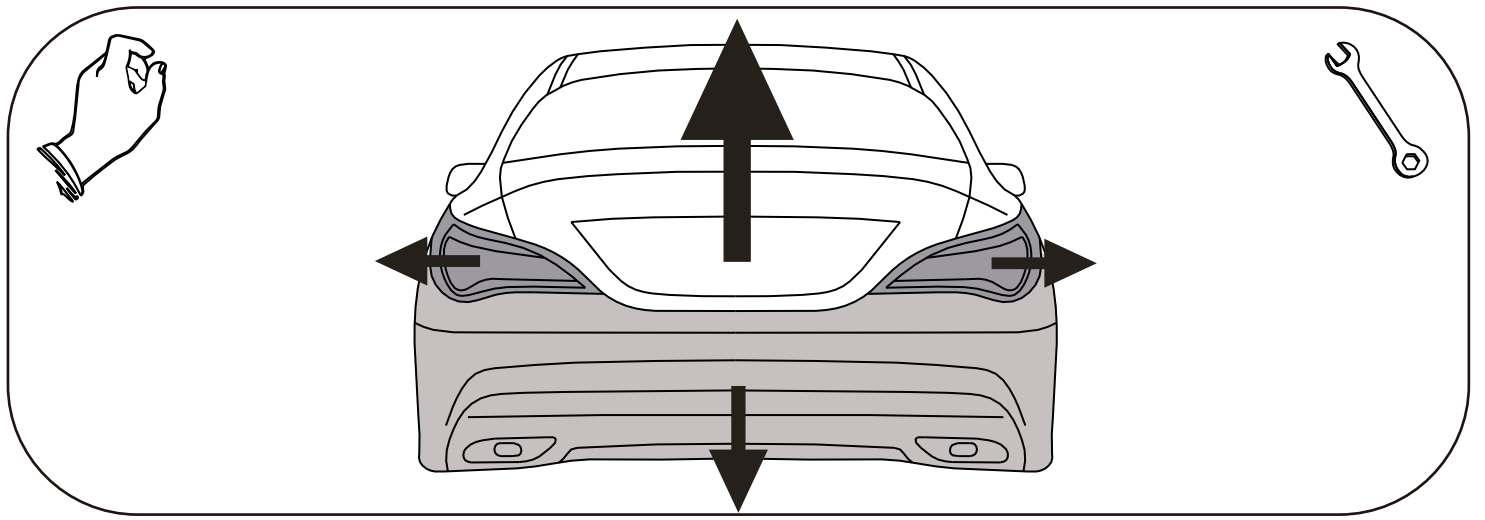

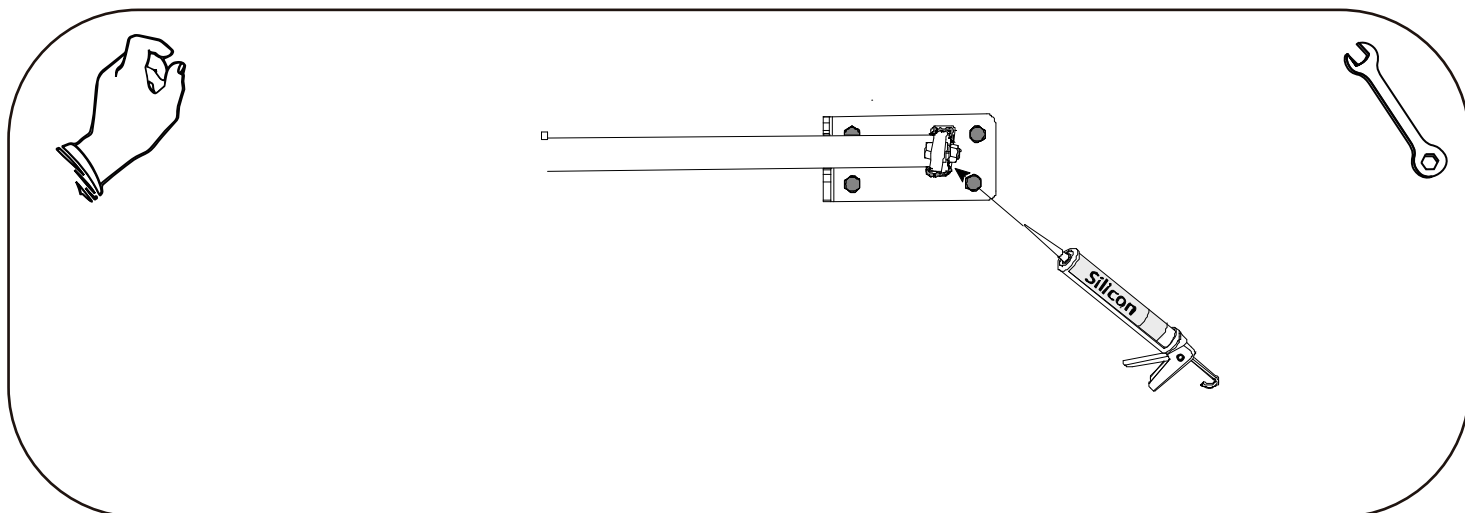
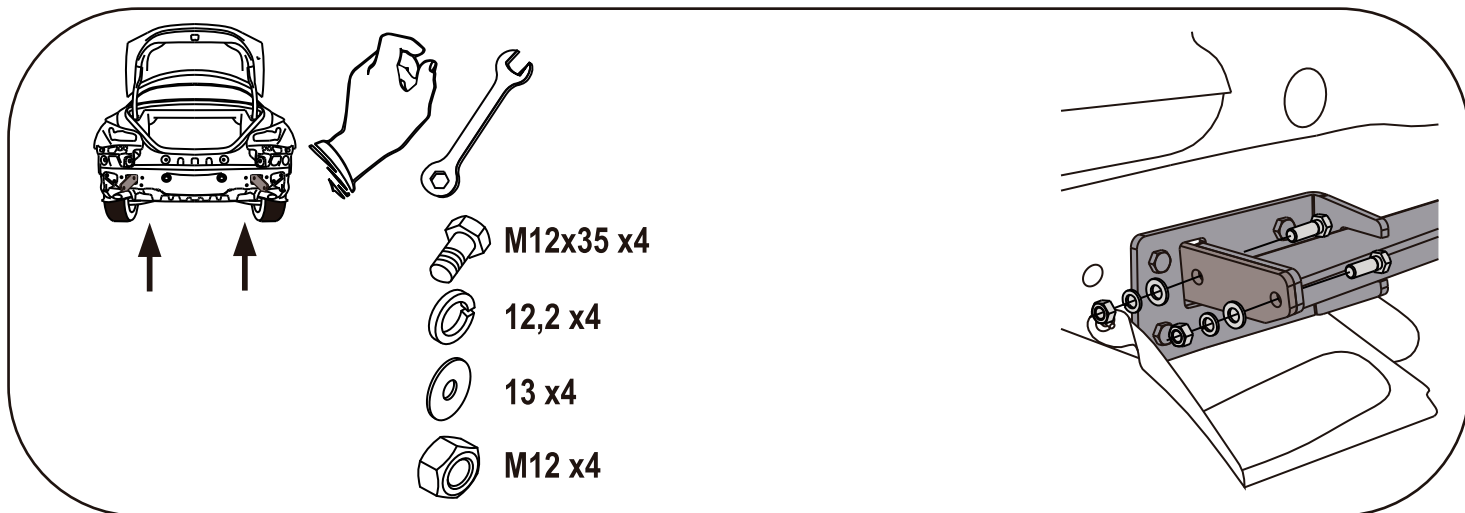
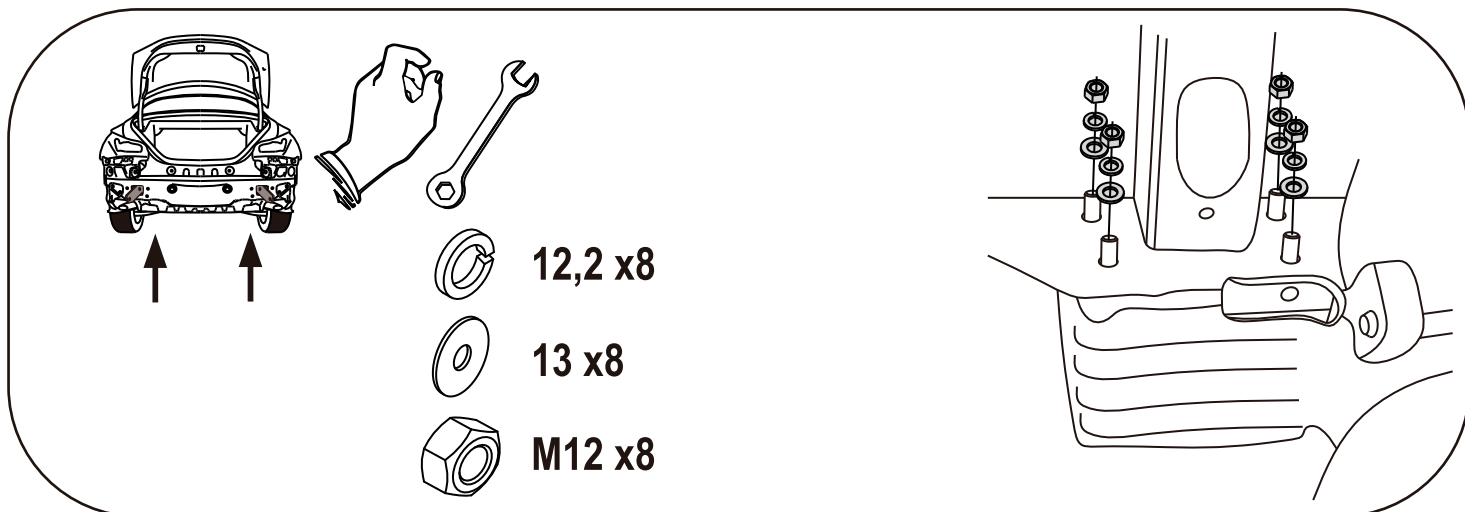

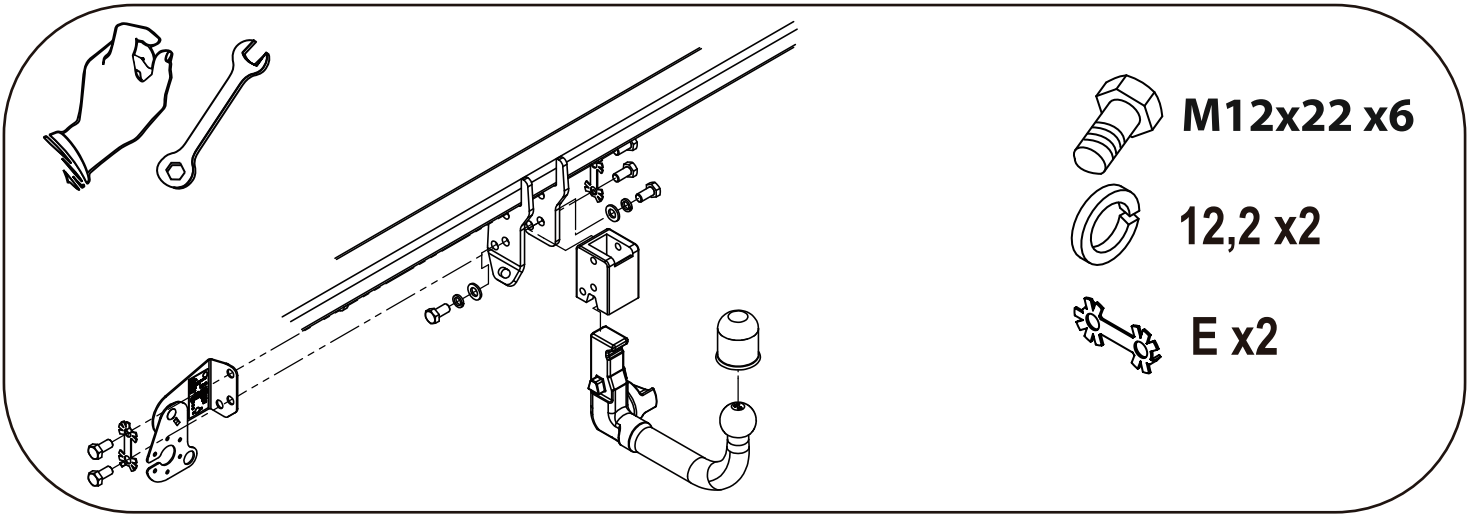
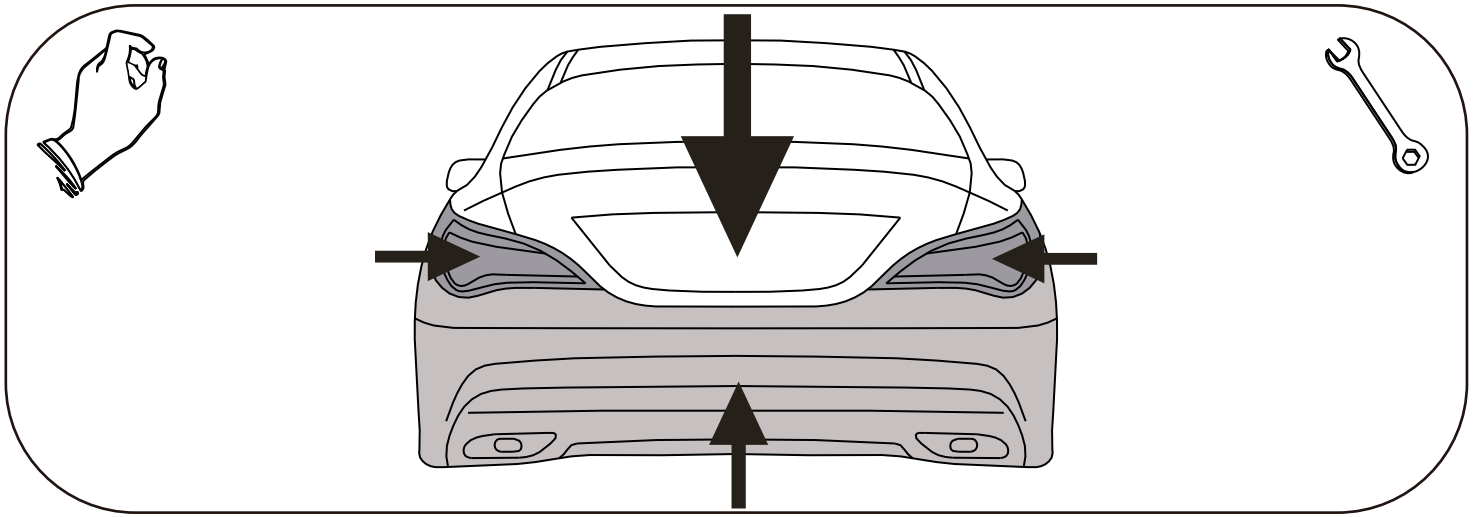



CRIMP

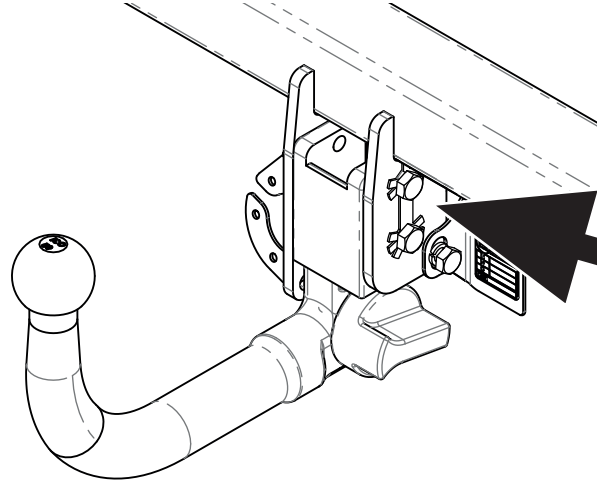
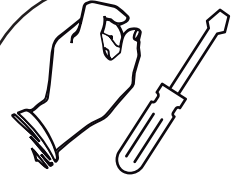
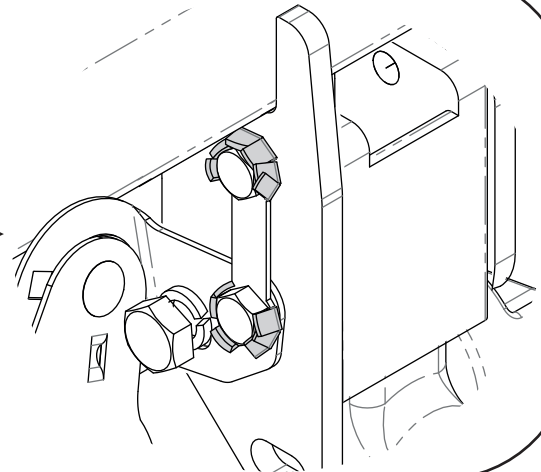
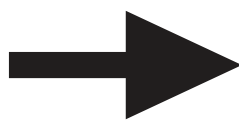
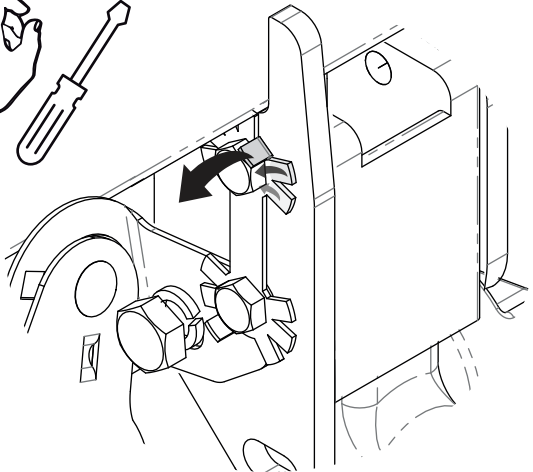
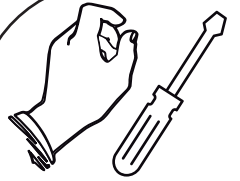
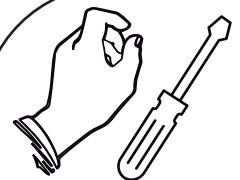
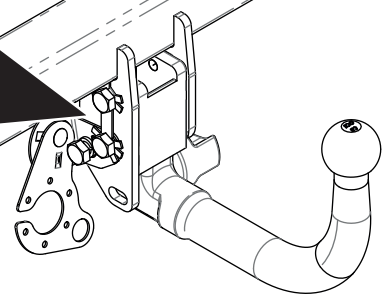

CRIMP

